

## CHAPTER 5

### TABLE OF CONTENTS

	Page
5.00 STORMWATER-DETENTION PONDS.....	5.00-1
5.01 Pond Design Criteria: SYSTEM DESIGN.....	5.01-1
5.02 Pond Design Criteria: POND LAYOUT AND SIZE.....	5.02-1
5.03 Pond Design Criteria: MAIN TREATMENT CONCEPTS.....	5.03-1
5.04 Pond Design Criteria: DEAD STORAGE VOLUME .....	5.04-1
5.05 Pond Design Criteria: EXTENDED DETENTION .....	5.05-1
5.06 Pond Design Criteria: POND OUTLET STRUCTURES .....	5.06-1
5.07 Pond Design Criteria: OPERATION AND MAINTENANCE.....	5.07-1
5.08 Pond Design Criteria: SPECIAL CONSIDERATIONS .....	5.08-1
5.10 STORMWATER POND SYSTEMS.....	5.10-1
5.11 Pond Systems: ON-SITE VERSUS REGIONAL PONDS .....	5.11-1
5.12 Pond Systems: ON-LINE VERSUS OFF-LINE PONDS .....	5.12-1
5.13 Pond Systems: OTHER POND SYSTEMS .....	5.13-1
5.20 Ponds: EXTENDED-DETENTION PONDS.....	5.20-1
5.30 Ponds: DEAD STORAGE OR QUIESCENT PONDS.....	5.30-1
5.40 Ponds: WETLAND TREATMENT .....	5.40-1
5.50 Ponds: MODIFIED DRY PONDS .....	5.50-1
5.60 TEMPORARY PONDS.....	5.60-1
5.61 Temporary Ponds: SEDIMENT BASINS .....	5.61-1
5.62 Temporary Ponds: SEDIMENT TRAPS.....	5.62-1
5.63 Temporary Ponds: TEMPORARY SEDIMENT-CONTROL PONDS .....	5.63-1
5.70 STORMWATER DETENTION POND DESIGN DETAILS AND EXAMPLES.....	5.70-1
5.71 Stormwater Detention Pond Design Details and Examples: SPECIFICATIONS .....	5.71-1
5.72 Stormwater Detention Pond Design Details and Examples: EXAMPLE OF A SIMPLE DESIGN .....	5.72-1
5.73 Stormwater Detention Pond Design Details and Examples: EXAMPLE OF A COMPLEX DESIGN .....	5.73-1

## **5.00 STORMWATER-DETENTION PONDS**

### ***DESCRIPTION***

This chapter focuses on the application of stormwater ponds as a best management practice (BMP) for improving the quality of urban runoff and reducing peak discharges. Stormwater ponds have become the most common “structural” method of regulating and treating stormwater runoff. A significant body of technical literature documents the favorable performance of stormwater ponds. Many municipalities and watershed districts require stormwater ponds to mitigate the adverse impacts of urbanization.

### ***PURPOSE***

This chapter recommends design features for stormwater wet detention basins and wetlands designed for urban stormwater treatment. Information contained herein does not replace the need to understand the site-specific design needs, nor does it supersede other requirements, such as applicable regulatory requirements.

### ***TREATMENT MECHANISMS***

Published stormwater-treatment literature indicates that ponds treat primarily by dynamic and quiescent settling of sediment particles. In addition to settling, treatment may also be accomplished by biological and chemical action, plant uptake, evapotranspiration, infiltration and, in some cases, physical diversion to other systems (USEPA, December 1983).

### ***TARGET POLLUTANTS***

If well designed, wet ponds and constructed wetland treatment systems are effective for removing sediment and associated pollutants, such as trace metals, nutrients and hydrocarbons. They also remove or treat oxygen-demanding substances, bacteria and dissolved nutrients.

### ***EFFECTIVENESS***

The Nationwide Urban Runoff Program (NURP) research projects determined that 90% removal of total suspended solids (TSS) appears to be an attainable goal in stormwater-treatment ponds. Significant removal of other pollutants, such as phosphorus, was also predicted to be achievable (USEPA, December 1983). Actual removal will vary due to site-specific conditions (see Figure 5.01-1).

## **5.01 Pond Design Criteria: SYSTEM DESIGN**

Many issues cut across the distinction between the planning and design phase of a project. Many tradeoffs must be assessed in the development of pond policy. Pond location, pond design type, pond ownership and pond policy flexibility are some of these issues.

Selecting the appropriate system design depends on many considerations. The project goals and objectives must be considered with the site physical limitations along with financial implications and political considerations. These issues are discussed in chapters 1, 2 and 3. Design factors to consider include the type of facility desired, variability of the rainfall and runoff, soil and cover types (see chapter notes 5.01-1 and 5.01-2).

Ponds can be built in a wide variety of designs and with a wide variety of features. Of course, different designs will have variable treatment effectiveness at different sites (see Figure 5.01-1). Good design must anticipate maintenance issues and should include community desires for aesthetics or recreation by incorporating desirable features into the pond design. However, there is a range of variability that should be understood within each type of pond. Even the expected performance of a particular design may be highly variable (see Figure 5.01-2). There is no single solution or design for all situations.

It should also be evident that given the number and type of variables involved, even well-designed ponds will not always perform as designed. Your plans should take this variability into account, since the best performance you can expect will be for the pond to meet the design criteria on an average annual basis. The standards presented here are an attempt to present reasonably implementable goals, which will provide an adequate level of water-quality protection. For critical situations and outstanding resources, additional or more stringent requirements may be necessary.

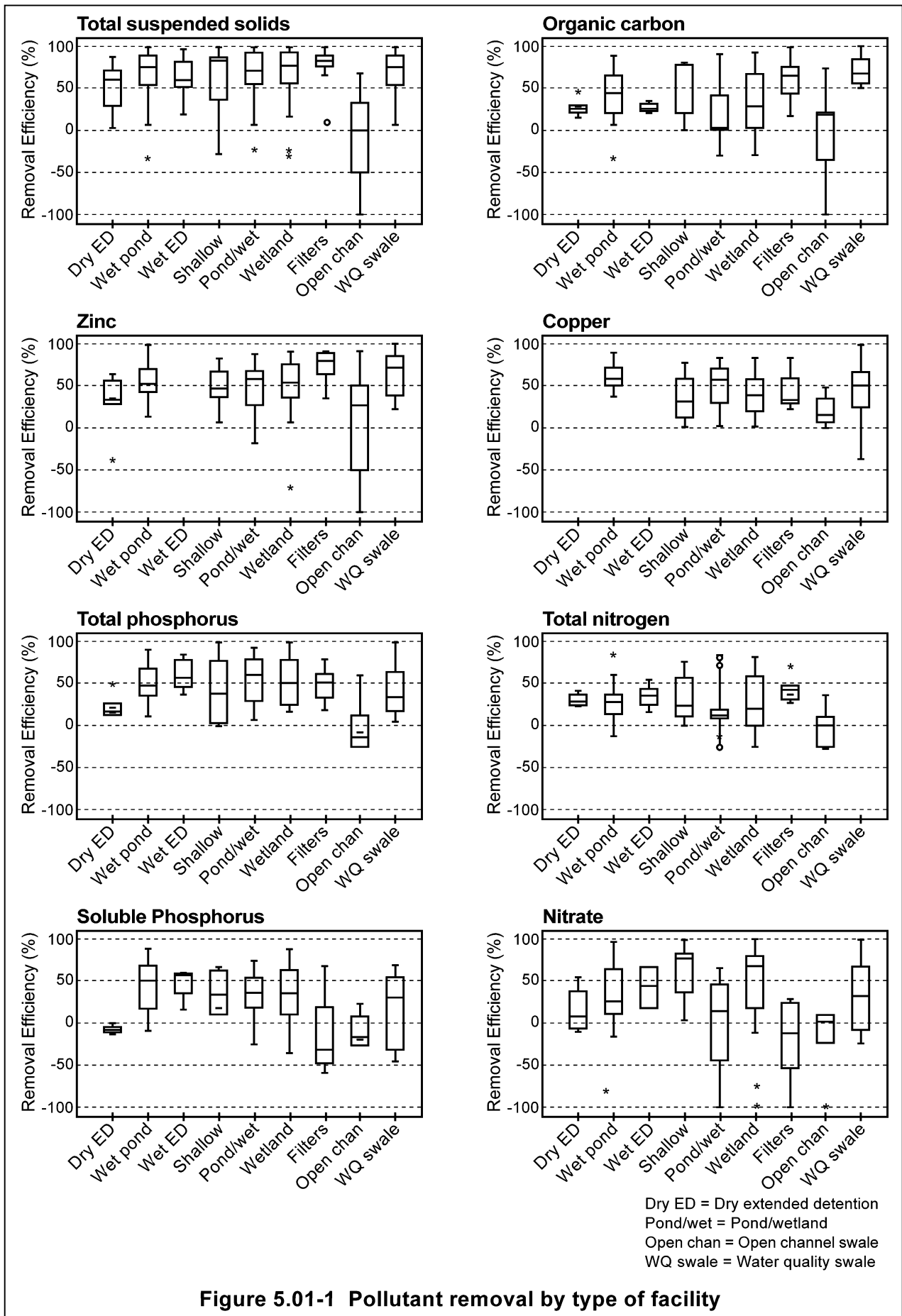

**Figure 5.01-1 Pollutant removal by type of facility**

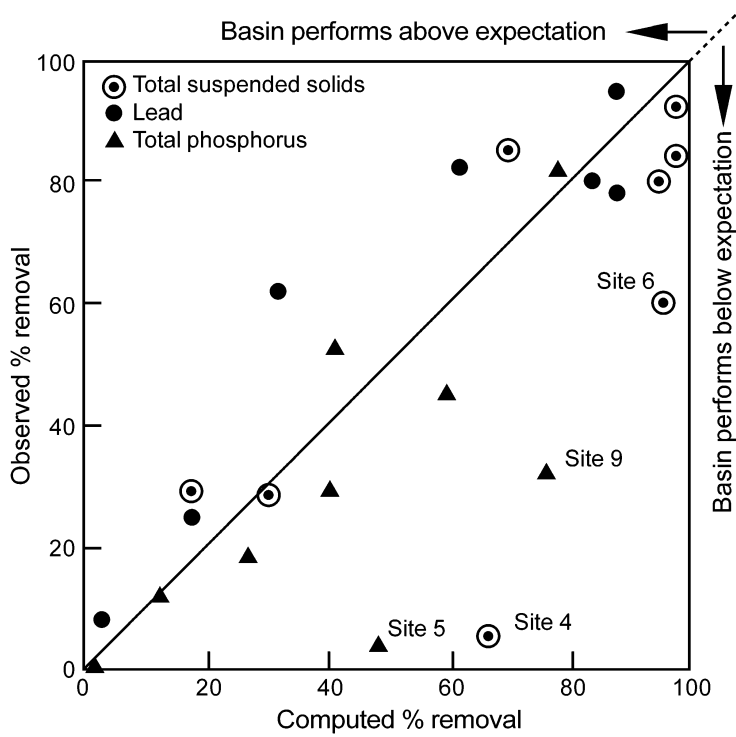

**Figure 5.01-2 Comparison of observed vs. computed removal efficiencies (percent removal of pollutants during monitored storms)**

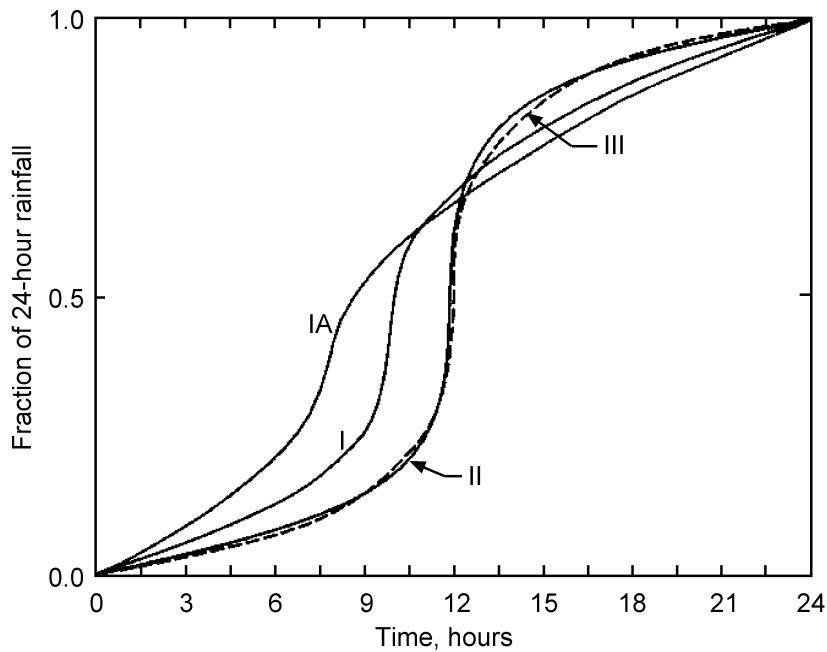

**Figure 5.01-3 Synthetic 24-hour rainfall distributions**

### **Note 5.01-1 Describing a Design Storm Event**

It is not enough to specify a rainfall amount in inches to describe a rainfall event. Before we can begin to talk about the runoff from an event, the nature of the storm event must be carefully considered. When talking about a storm event, we mean a storm with a certain amount of rainfall, such as a 1.25- or 2.5-inch event. But this alone is not all of the storm information needed for design purposes. For the purpose of designing ponds or other devices, it is important to understand the assumptions that are implied in the adoption of the design storm. The factors that need to be defined to describe a storm include volume, duration, intensity and distribution, and frequency.

**Volume:** This is the volume of rain that occurs for the given storm. The volume of the event is often the only information given, but it is not enough to describe the storm for design purposes.

**Duration:** Duration of a storm is the time over which it occurs. This manual assumes the event occurs over a 24-hour period. However, an infinite variety of storms can occur over a 24-hour period, even those that have the same amount of total rain. This is due to differences in the intensity and distribution of the rainfall.

**Intensity and Distribution:** Intensity is the rainfall stated in inches per hour. However, rainfall intensities vary from storm to storm and in most events are not constant during the storm. Constant rain may be an acceptable assumption over four hours, but it is probably not good over a 24-hour period. Therefore, we also need to describe the distribution of the storm, which is how the intensity of the storm changes through the storm's duration. This manual assumes the Natural Resource Conservation Service (NRCS) storm types, which for Minnesota is the Type II storm distribution (see Figure 5.01-3). This is one of the more commonly used distribution assumptions. The assumptions built into any distribution should be fully understood in order to properly apply hydrologic principles to your project.

**Frequency:** Frequency is the recurrence interval or the reciprocal of the probability. The size of storm we can expect to occur at any given frequency changes across Minnesota from northwest to southeast from about 1.8 to 2.6 inches for a one-year, 24-hour storm. This means that an annual event is much smaller in northwest than in southeast Minnesota. When frequency of recurrence is important, this must be taken into account. The recurrence interval in this manual is usually assumed to be for rainfall events with a distribution for events measured at the Minneapolis-St. Paul airport.

We refer to specific storm events to establish a common ground of design. This can only be effective if the assumptions are understood and properly applied in a given design situation. Determining whether these events or assumptions are appropriate for your project must be done on a site-specific basis. Remember, a design storm does not reflect actual events, but should reflect the typical assumed conditions for which the design is intended.

**Note 5.01-2 Particle size assumptions**

There is a wide range of particle sizes and composition, and hence, settling velocities, in any sample of stormwater runoff. This range can be described by a probability distribution of pollutant settling velocities and determined by an appropriate analysis of the data obtained from standard settling column tests. When the settling velocity distributions obtained from the NURP studies were analyzed, differences were found between storms at a site and between storms at different sites. Site-to-site differences were of the same order as storm-to-storm variations at a particular site, justifying the combination of all data. The result of such an analysis, illustrated by Figure 5.01-4, indicated that it is reasonable to make estimates of “typical” urban runoff settling characteristics and expect that, in an appropriate analysis, short-term variations will average out. This assumption and the relationship shown, proved to work out quite well in the analysis of the performance of nine detention basins in different parts of the country that differed radically in size.

While the “typical” values provided here are considered to be satisfactory for initial estimates and for screening analyses, additional site-specific settling column studies are encouraged to expand that database and improve site-specific estimates.

(From: U.S. Environmental Protection Agency, 1986)

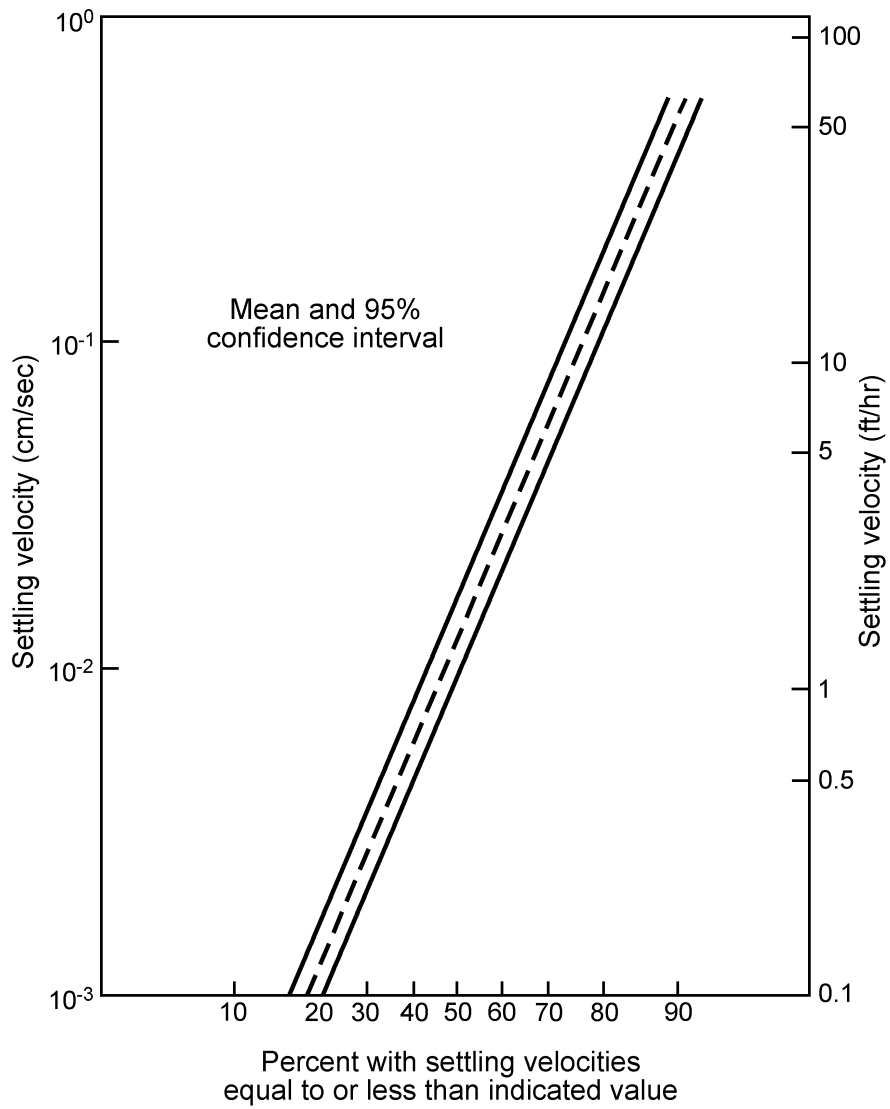

**Figure 5.01-4 Particle size settling velocity probability distribution**

## **5.02 Pond Design Criteria: POND LAYOUT AND SIZE**

Often, the pond is divided into three zones: (1) an inlet, which can have a deep pool or other design for flow dispersal; (2) the main, or primary, treatment area; and (3) an outlet zone, which can be deep to prevent resuspension or be designed for final “polishing.” The main treatment area of a pond is typically located between its inlet and outlet areas. Multiple ponds or pond wetland systems can also provide these design features, but the function of the zones remains essentially the same.

### **INLET DESIGN**

Pond design normally includes an inlet area with a permanent sediment storage area 3 to 8 feet (ft) deep. This storage starts below the inlet spillway elevation and extends downward to what can be the deepest point in the pond. In general, this area should have a design that provides energy dissipation, sediment storage and some quiescent settling.

#### **Inlet Sediment Storage**

An inlet area 3 to 8 ft deep (with an area 10-20% of the total area of the pond) is recommended. The inlet is the zone where the largest sediments will settle out and, therefore, will need to be removed periodically. Access to the inlet areas should be provided to facilitate maintenance and repairs.

#### **Scour Control**

Scour is the erosion of pond bottom or bank material due to high flow velocities. Scour control is important to maintain the function of the pond and reduce erosion, especially near the inlet. Inlet areas and inlet structures should be designed to control velocities at the inlet whether from large or small storm events.

Flow-diffusion devices, including plunge pools, directional berms or other specially created dissipation structures, are often recommended. For annual events, the velocity leaving the inlet area and entering the main treatment area should be less than 1 ft per second (fps). Decreasing velocity reduces scour and more importantly reduces mixing currents that reduce treatment efficiency.

### **OUTLET DESIGN**

The outlet area should be a deeper micropool to provide final settling and prevent resuspension of sediments. The outlet device should be carefully designed, since it is important to the operation of the entire pond system. Pitt (1994a and April 29-30, 1998) found that a ratio of approximately 5.66 cubic feet per second (cfs) of outflow for each acre of pond surface area resulted in a predicted sediment trapping efficiency of approximately 90%. This conclusion is based on urban storm water with particle size distribution found in Madison, Wisconsin, runoff. Outlets with this design can be expected to meet the stated NURP goals (USEPA, 1983) on an average annual basis.

## MAIN TREATMENT AREA

Field studies of wet stormwater ponds in the NURP program reveal that 90% removal of TSS is attainable with a pond surface area that is about 1% of the watershed area. Pitt (1994a and 1998) studied the pond-surface-area-to-watershed-area ratios and found that open-space watersheds with highly permeable soils require less pond surface area, down to about 0.6% of the watershed area.\* He also found that ratios varied, with requirements of 0.8% for residential land use areas and 1.7% for commercial areas, up to 3% for totally paved areas (see Table 5.02-1). An estimate of 1% is often used for watersheds with mixed land use, but this must be analyzed on a site-specific basis.

**Table 5.02-1 Wet pond surface area required as a percent of drainage area , for a given land use and goal of 90% sediment removal (Pitt, 1998)**

Land Use	Percent of Watershed
Totally paved areas	3.0
Freeways	2.8
Industrial areas	2.0
Commercial areas	1.7
Institutional areas	1.7
Construction sites	1.5
Residential areas	0.8
Open spaces	0.6

### Shape and Appearance

Flow length and path through the pond affects settling performance. Conventional design dictates that, when the pond is considerably longer than wide (*e.g.*, three times as long as wide), it will likely provide additional detention time for settling and biological treatment of runoff. However, an oblong or rectangular shape does not guarantee that short-circuiting will not occur. Excessive inlet velocities, wind or thermal currents can cause sediment movement, resulting in short circuiting in the pond and inefficient use of the entire pond volume.

Landscaping of upland areas adjacent to stormwater ponds is frequently incorporated into final design plans. In many cases, parkland or recreational trails exist alongside stormwater-treatment and storage ponds. Cities and watershed districts often play a major role in determining landscape features. They should develop policies that encourage functional and aesthetic landscaping practices.

### Flow Patterns

Baffles and curved flow paths are often used to increase settling efficiency. Schueler (October 1992) uses the natural-looking variation in bottom contours to enhance flow characteristics in his wetland designs (see Figure 5.02-1). The actual dynamics of flow and sedimentation in stormwater ponds relative to the pond shape are not well described in available literature. Design of stormwater-treatment ponds remains a developing technology.

---

\* The Ramsey-Washington Metro Watershed District finds that a 0.5% ratio is often acceptable. Note: these numbers may need to be adjusted upward for small watersheds (see Special Considerations).

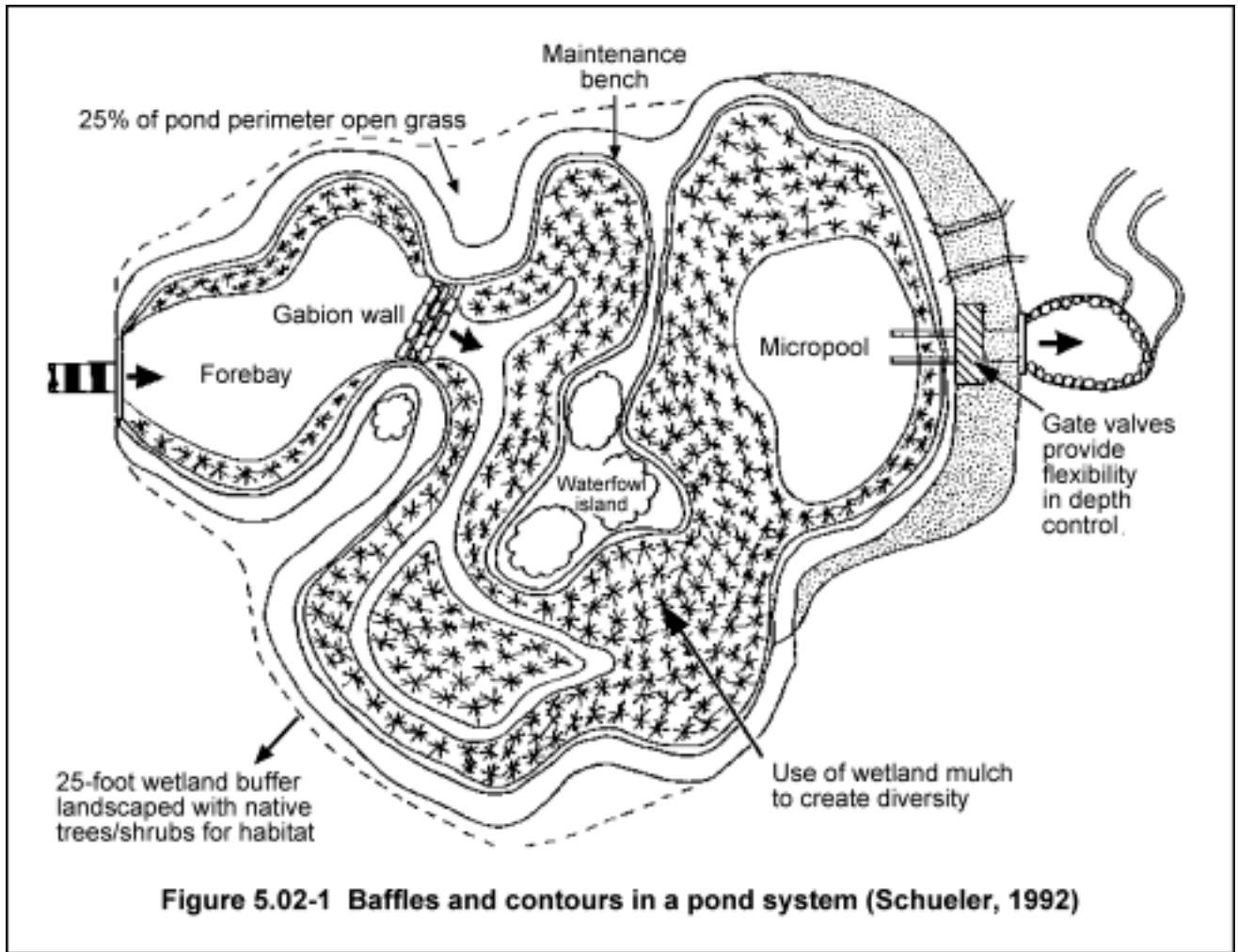

## 5.03 Pond Design Criteria: MAIN TREATMENT CONCEPTS

### ***DESCRIPTION AND PURPOSE***

The main treatment area may be a wetland, deep pond or any combination that meets the design criteria for the project. In general, the main treatment area is designed to provide an area for settling of the fine to medium-size particles (*i.e.*, 5 to 100 microns in diameter) in urban runoff. It typically constitutes 30-80% of the total volume of the stormwater pond. The main treatment area may be designed to provide a suitable habitat for various types of wetland plants and associated wildlife species. In some instances, open water may be desired for sediment storage or aesthetic reasons.

### **Water Quality Volume**

The water quality volume is defined in terms of the effectiveness of the treatment on an average annual basis. If the removal goal for the water quality volume is 90%, then the removal for lower flows will be higher, but higher flows will have less removal. We cannot design for 90% removal from all storms, so we calculate a design storm that will give us 90% removal on an average annual basis. The assumptions and variability required to estimate this type calculation are discussed in *Methodology for Analysis of Detention Basins for Control of Urban Runoff Quality* (USEPA, 1986).

Properly conducted, the design water quality volume would give the equivalent of the “flow weighted mean removal rate,” for a given particle size, rainfall and runoff distribution characteristics of the site. It could reasonably be expected that 20 years of data for each site would be required to get statistically significant data that could be applied to this type of calculation. By making reasonable assumptions and by using data and practical applications from across the country, Pitt (1994a), Walker (1987a and 1987b) and others have come up with suggested design parameters.

### **Sizing for Treatment (Pitt Method)**

The Maryland Department of Natural Resources (Barfield *et al.*, 1986) indicates that the ratio of pond surface area to peak discharge is a practical criteria for design of sedimentation ponds. Our evaluation indicates that this ratio is also easier to compute and apply as a practical design tool than detention time, and it can be more readily field checked for compliance.

Pitt found that a ratio of approximately 5.66 cfs of outflow for each acre of pond surface area resulted in a predicted sediment trapping efficiency of approximately 90% in urban storm water with particle size and rainfall distribution found in Madison, Wisconsin, runoff (Pitt, April 29-30, 1998). Thus, the treatment goal for wet ponds is to remove about 90% of the suspended solids by using a design ratio of 5.66 cfs of pond outflow per acre of pond surface area.

When Wisconsin Department of Natural Resources staff analyzed the water quality volume using Pitt and Walker models for local conditions, they found that the assumptions, such as particle size distribution, were critical to the calculations (Personal communications). Although their goals, assumptions and analysis methods differed somewhat from those used in this manual, they concluded that a water quality volume based on 1.25- to 1.5-inch events would provide a reasonable average

annual removal rate of 80%. The design recommendations of this manual are more conservative than the assumptions used in their modeling; therefore, their conclusions support this manual's 90% goal.

Pitt provides an explanation and reasonable estimate of the return frequency event for 90% overall removal of suspended solids in urban areas of the Upper Midwest. He proposes the 1.25-inch event (Pitt, 1998). This is about the 0.3-year return frequency, or the event occurring about three times per year.

Using the Pitt method, the stage and discharge for the pond spillway are designed so that the maximum flow out should be less than or equal to 5.66 cfs per acre of pond surface area. The maximum discharge should occur when the elevation of the pond has the entire water quality volume. Using the entire water quality volume and specific outflow rate as the design criteria also makes it relatively easy to field check the as-built structure to see whether it complies with the criteria.

### **Sizing for Treatment (Walker Method)**

Another estimate of the water quality design is provided by Walker in his report to the Vadnais Lakes Area Management organization (see Walker, 1987b). Walker proposed storage with a permanent volume equal to the 2.5-inch event. This is twice as big an event and more than twice the water quality volume recommended by Pitt. The differences between Pitt and Walker are large, but you need to consider the basis of their design and assumed removal mechanisms. Pitt design methods are primarily directed at suspended solids. Pitt methods may require a smaller initial volume but also require carefully controlled release and bounce in the pool. Walker-design ponds are primarily directed at phosphorus removal. They require a large storage for inter-event treatment, but do not require controlled release. Therefore, bounce in the pool is not part of Walker design calculations.

This manual has attempted to resolve the differences in these widely accepted design recommendations by allowing both options. Using either design option can be reasonably expected to meet water-quality goals, provided that control of velocity in the pond to prevent resuspension of sediments, and other specific conditions of design are complied with.

### **Calculating Water Quality Volume**

The volume of runoff from the water quality event is best predicted by a combination of monitoring existing conditions and modeling future conditions. For design purposes, the water quality volume should be considered an instant flow to the pond, not an inflow-outflow calculation. Both Walker and Pitt use this assumption (Walker, 1987a and b, and Pitt, 1994a). The assumption of instant runoff is conservative, but it accounts for a great deal of the variability that occurs in storm events and runoff conditions.

### **Bench Areas**

Stormwater-treatment ponds should be designed with shelves or benches that slope gradually into the open-water area and form a transition between the open-water area of the pond and the surrounding property. A 3- to 10-foot bench should be constructed. Slopes of 10:1 (10 ft horizontal to 1 ft vertical) to 6:1 are recommended. When enough area is available, a 10-ft bench with a 10:1

slope is recommended. Bench areas may comprise 10-20% of the total pond area. Emergent vegetation, such as cattails and grasses, should be encouraged, but often they will grow voluntarily on bench areas (see Figure 5.03-1).

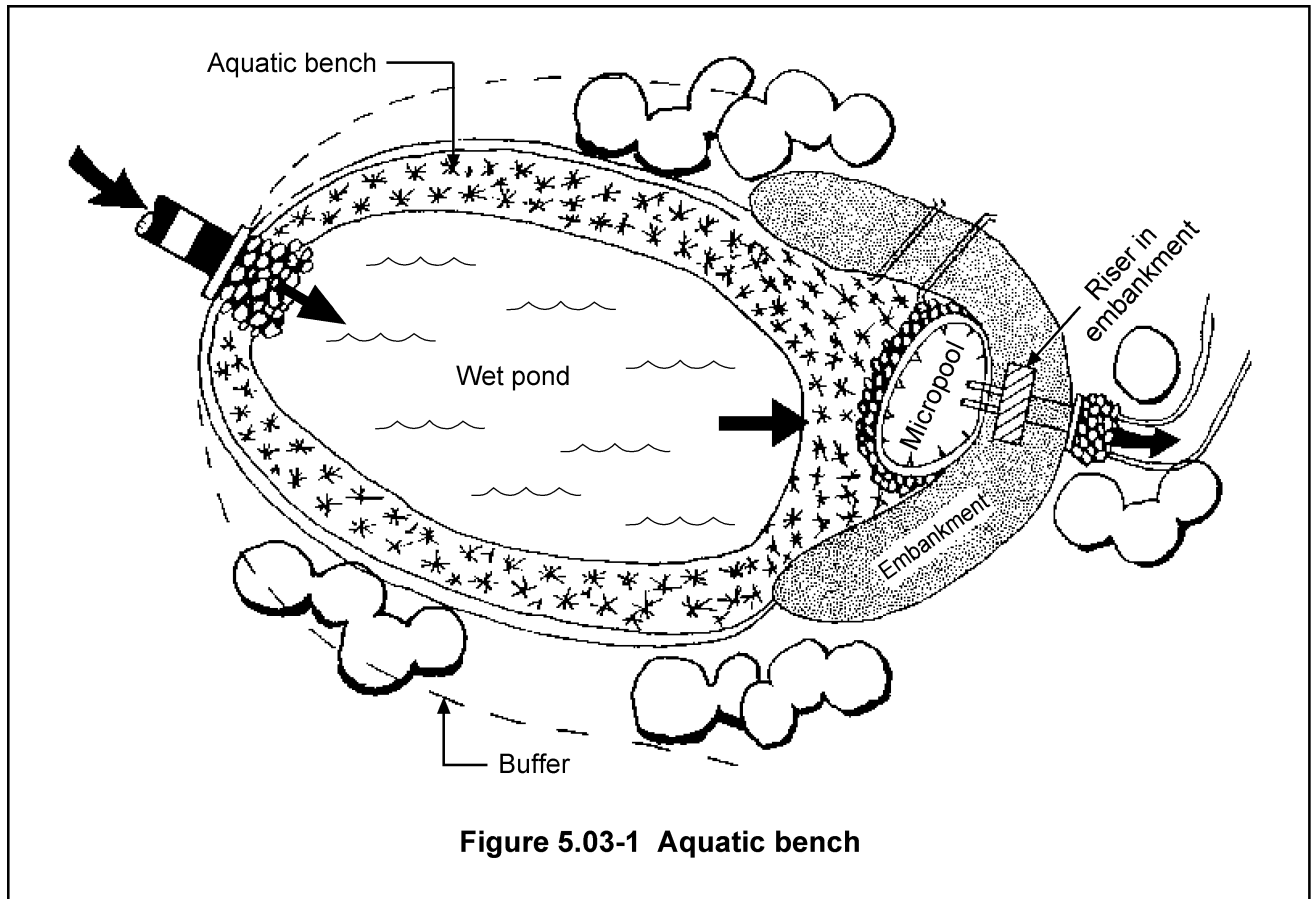

### Wetland Vegetation

Aquatic vegetation provides some aquatic nutrient uptake, prevents erosion and provides an aesthetically more pleasing and perhaps more effective way of removing nutrients than other measures. Walker (1990), in documentation for his P8 model, also indicates that there is evidence that vegetation in a pond or wetland may provide increased settling effectiveness by laminar settling. In these cases, vegetation slows flow and acts like settling plates to remove suspended particles.

Vegetated bench areas also provide wildlife habitat and help prevent children from entering open-water areas. In addition, vegetated bench areas discourage the use of adjacent grassed areas by geese. Geese prefer open, grassy areas and tend to overpopulate mowed park areas that are immediately next to open water.

## **Wetland Designs**

Wetlands treatment systems should be designed using the surface outflow rate method discussed in this manual as the main water quality treatment design mechanism. We encourage the use of wetlands for treatment, but detailed designs of wetland treatment systems are beyond the scope of this manual. Wetlands may reduce dead storage, but can provide added benefits that make up for the dead-storage loss. Wetland systems must be designed in consultation with professionals who are knowledgeable in the field of wetland design, construction or restoration. Refer to the section on “Special Considerations” below and refer to experts, such as Schueler, Dindorf, Eggers and others in the references for further information.

Unless carefully designed, discharges to wetlands may disrupt the wetland systems to such an extent that they destroy the wetland vegetation and habitat values. Therefore, discharges to natural wetland systems should generally not be allowed or given treatment credit, or allowed unless there are no other available options. Allowing discharges to natural wetlands without pretreatment and rate controls should be avoided wherever possible.

## 5.04 Pond Design Criteria: DEAD STORAGE VOLUME

### *DESCRIPTION AND PURPOSE*

There are three distinct storage areas in a pond: (1) the stormwater drainage control volume, (2) the water quality volume and (3) the storage volume below the pond outlet, often called “dead storage” (see Figure 5.04-1). The purpose of dead storage is to help diminish velocities, reduce scour, encourage quiescent settling of sediment and provide sediment storage volume. However, there are potential problems with any large permanent storage volume.

### **Potential Problems with Dead Storage in Ponds**

Large dead-storage volumes in urban stormwater ponds can be related to elevated temperatures. Deep pools may turn anoxic and release pollutants, such as nutrients and metals. Depths over 8 ft are not encouraged, but this effect can occur in shallower pools as well. The Minnesota Pollution Control Agency (MPCA) has observed this effect in wastewater-treatment ponds less than 4 ft deep (Helgen, 1992).

### **Benefits of Dead Storage**

Dead storage provides additional settling and potential biological treatment between rainfall events. Methods (USEPA, 1983) based on DiToro and Small (USEPA, 1986) assume a settling velocity and multiply it by the pond treatment area to determine the volume of treated water between events. When considering inter-event treatment, a volume limitation (no more treatment credit than the volume of the pond) and an efficiency factor should be applied because wind and thermal currents significantly reduce the theoretical removal rates for fine particles (Fair and Geyer, 1954).

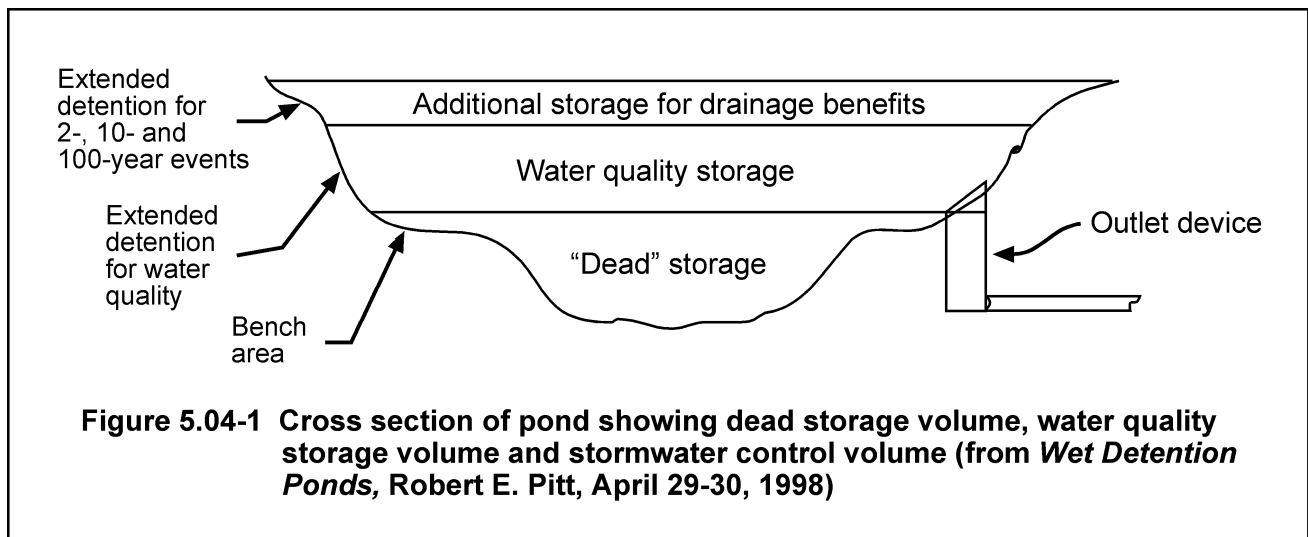

In ponds designed to use the dead storage as the primary treatment, the pond storage volume is often large to allow possible biochemical treatment and quiescent settling to occur. Dissolved phosphorus (P) and other substances with dissolved fractions are some of the parameters where additional pond retention time may allow biological or chemical treatment to occur. Pond volume is increased to lengthen residence time, and potentially provide biological and chemical removal. The use of pond design storms from 2.0-inch (Brach, 1989) to 2.5-inch rainfall events (Walker, 1987b) reflects this concern for additional volume.

If the dead storage volume is designed to incorporate the water quality treatment volume, that means that the design does not rely on treatment by extended detention above the outlet. The dead storage volume provides sediment storage, flow diffusion and other purposes in addition to settling. Therefore, the volume below the outlet needs to exceed the water quality volume to provide equivalent treatment. This manual recommends that the dead storage volume be capable of holding an instant runoff volume from an event twice the water quality event; in other words, it should hold the runoff from a 2.5-inch event. This volume is adapted from the Walker pond design, which is accepted by many jurisdictions in Minnesota (Walker, 1987b).

Ponds with large dead storage volumes can provide adequate treatment if the displaced water quality volume is the quiescently treated water in the pond. When sufficient extra volume is provided, the design outflow rate of 5.66 cfs per acre of surface area for the water quality volume is usually met, but need not be strictly complied with.

Whether dead-storage pond designs meet the outflow rate criteria or not, they should provide velocity and scour reduction and meet other design criteria described in this manual, or be modified to do so. To prevent resuspension of sediments, ponds with large dead storage volumes must meet the velocity requirements in the pond for the 0.3-year (water quality event) event, and the one-, two-, 10- and 100-year events (Table 5.10-1). Generally, this can be checked by routing the various storms through the pond and calculating the discharge divided by the critical cross section. The high-flow events (two-, 10- and 100-year events) should also have peak discharge rates less than the predevelopment discharge.

### **Sediment Storage**

Sediment volume should at least conform to applicable MPCA permit requirements. If the pond uses dead storage instead of extended detention as its treatment system design, keeping adequate storage is an important consideration. We recommend that when possible the pond should be built with capacity for about 25 years of storage. As a practical matter, larger particles in the sediment will tend to accumulate near the entrance to the pond. Therefore, more frequent maintenance will probably be needed at the entrance area no matter what the total pond sediment capacity may be. Properly designed inflow areas with easy access can reduce total maintenance costs over the life of the system.

A detailed analysis of pond sediment storage volume may be helpful to determine cost-effective sediment-control plans. Methods, such as the NRCS and universal soil loss equation, can be used to estimate sediment volume from a watershed and, therefore, can be used for sediment storage sizing. To be properly applied, they should be evaluated by professionals on a site-specific basis.

Here is one method of calculating the basic sediment equation and design considerations:

$$\text{Volume} = \frac{E \times DR \times TE \times A \times Y}{217,800 \times G}$$

where:  $Vol$  = design sediment storage capacity,

$E$  = average rate of erosion in the watershed in tons per acre per year,

$A$  = area of the watershed in acres,

$DR$  = sediment delivery ratio in percent,

$G$  = estimated sediment density in the basin in pounds per cubic foot,

$TE$  = trap efficiency in percent, and

$Y$  = design storage period in years.

Table 5.04-1 compares some benefits and potential problems of using pond designs which use permanent volume below the inlet verses those that use extended detention storage.

**Table 5.04-1**

<b>Permanent Volume Below the Outlet</b>	<b>Benefits</b>	<b>Potential Problems</b>
<b>Shallow water (&lt;3' deep)</b>	Settling, vegetative filtering and biochemical treatment. Habitat creation can be aesthetically pleasing.	Needs careful design to prevent scour and vegetation die-off. Fall die-off may release trapped nutrients.
<b>Deep Water (3-8' deep )</b>	Reduces scour, provides sediment storage volume, provides retention time for quiescent settling and biochemical removal.	Elevated temperatures may cause depleted oxygen and release of nutrients and metals, potential aesthetics problems.
<b>Extended Detention Volume</b>		
<b>Water quality volume and flow attenuation volume ( 0 to 3' above normal pool)</b>	Maximizes settling removal. Provides flood control, multiple uses in semi-wet areas. Less permanent loss of upland.	Can be habitat trap due to bounce. Needs plantings adapted to fluctuating levels.

## **5.05 Pond Design Criteria: EXTENDED DETENTION**

### ***DESCRIPTION AND PURPOSE***

The extended detention volume of wet detention basins is the volume above the outlet or normal pool elevation, commonly called the bounce. It uses the semi-wet areas above the permanent pool for treatment and includes the water quality treatment volume and flood storage volume (see Figures 5.04-1 and 5.05-1). It is intended to accommodate inflow from small to much larger storms. For storms with a recurrence interval of about one year, the maximum bounce (water elevation increase) above normal pool usually should not exceed 3 ft. The extended detention volume should be drawn down in one to two days after a storm event to prevent destruction of adjacent vegetation by inundation, and to help assure the basin is ready for the next storm. In the Minneapolis-St. Paul area, the time between rainfall events is typically 87 hours.

### **Water Quality Treatment Volume**

To provide 90% overall removal, a design criterion needs to be established which will provide reasonable treatment given the assumptions about storm events, particle size distribution and settling velocities. To standardize design methods, we have selected an outflow ratio of 5.66 cfs per surface acre of treatment pond. This outflow rate has been selected to provide 90% removal for a volume equal to the runoff from the 0.3-year-return-frequency event. This is about 1.25 inches of precipitation in the metropolitan area. Note that, in accord with the discussion in part 5.03, the water quality treatment volume is calculated as an instantaneous volume, not an inflow outflow calculation.

The water quality volume required must be at least as large as the applicable MPCA permit requirements, which is 0.5 inch of runoff over the impervious surface (MPCA, Construction Storm Water Permit). The 0.5-inch criterion is intended to be a simplified calculation of the runoff volume from the 1.25-inch event in residential areas. However, it is often best to perform a hydrologic analysis of the watershed and design using the greater of these volumes.

### **Controlling the Two-, 10- and 100-year Events**

Urbanization will increase the runoff volume that occurs from each storm event, overloading the natural drainage systems that had adapted themselves to the pre-existing conditions. The frequency of bankfull and over-bank events usually increases with urbanization of the watershed. The stream attempts to enlarge its cross section to reach a new equilibrium with the increased runoff volumes and discharge rates. The erosive force of the increased channel flows can significantly upset the sediment-load equilibrium that has established itself over time, and may result in the stream meandering or forming new channels (Rosgen, 1994). Therefore, stormwater system design needs to consider both rate and volume control.

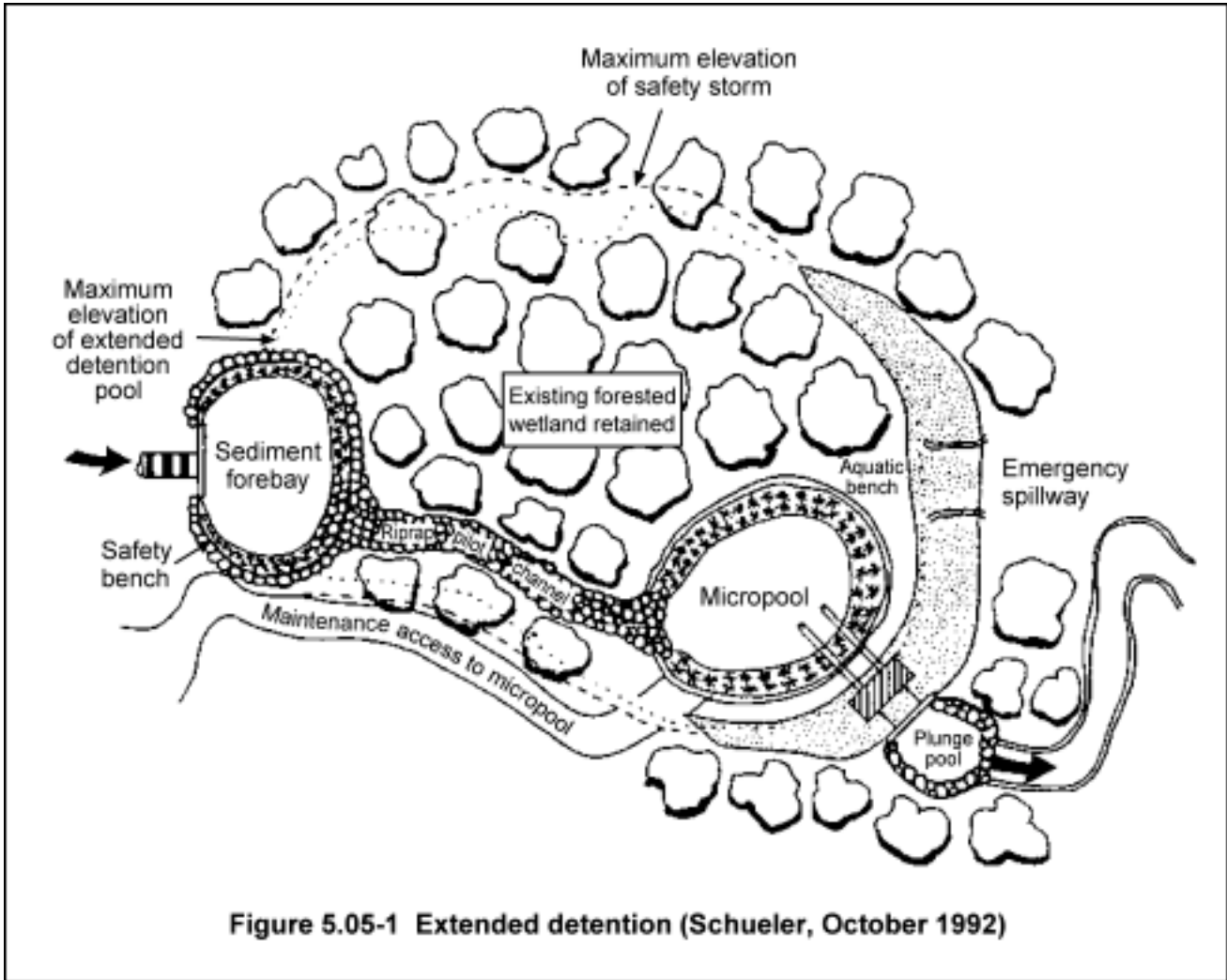

### Two-year Event Control

By reading the output from models such as TR20, we see that ponds can reduce peak discharges to less than the predevelopment rate. But ponds do not usually decrease the total volume of runoff. Analysis at most sites clearly shows an increase in runoff volume from predevelopment conditions, even when the peak discharge from developed conditions is held to predevelopment peak discharge rates or less. This is because the duration of discharge is extended proportionately. Since 1.3- to two-year events are approximately bankfull, and bankfull events are usually the most erosive per unit of flow, this increase in duration can significantly increase erosion problems for the downstream watershed, even for small storm events.

As a result of postdevelopment erosion problems, many states, including Maryland and Washington, and some watershed districts have proposed or developed policies on erosive flow controls. Washington has pond rate control policies that restrict postdevelopment flow to one-half the predevelopment flow for the two-year event. Maryland (Schueler, 1998) has proposed recharge volume requirements as well as retention for new development.

The significance of the large flood events should not be underestimated, and needs to be incorporated in the design. But in addition, the cumulative effects of the smaller but more frequent and cumulatively significant events need to be given sufficient consideration for protection of water quality, property and habitat.

### **Flood Control Goal**

Many watersheds require that postdevelopment runoff must equal the runoff from the 10- and 100-year predevelopment events. In addition, low floor elevations of structures are typically required to be at least 0.5 to 3.0 ft above the 100-year flood elevation. These rates and elevations need to be considered in the pond-design phase, in addition to the water quality treatment and erosion control design.

### **Addition Flow Reductions**

Watershed analysis may lead designers to conclude that the downstream system will be better served if we can reduce outflows more than the general guidelines contained here. Discharges to wetlands should be restricted in accordance with the guidance developed by the Storm Water Advisory Group (Minnesota, State of, Storm Water Advisory Group, June 1997). This guidance recommends limiting the change in the hydrologic character of a downstream wetland based on its vegetation types. Total volume reduction should be the preferred option, but adding a relatively small volume of additional storm event storage in upstream basins may be a cost-effective measure to minimize downstream impacts when there is limited capacity in the downstream system.

## **5.06 Pond Design Criteria: POND OUTLET STRUCTURES**

### ***DESCRIPTION AND PURPOSE***

Outlet structures control the outflow from the pond, which determines the flow in the pond and determines the treatment capabilities of the facility. They can also provide options for unusual operating conditions, such as drawdown of the structure for maintenance.

#### **Outlet Area**

In addition to the inlet and main treatment area, a stilling pool, 3 to 8 ft deep, is recommended as part of the wet pond design. This pool is usually located at the outlet and is sized to reduce outflow velocities to levels that prevent scour and resuspension. The outlet structure should be designed to work in conjunction with the stilling pool.

#### **Outlet Design Options**

Outlet or spillway design is crucial for effective stormwater treatment and for controlling flood discharges to downstream drainageways and receiving waters. It also affects the velocities in the pond. The design must allow treatment (90% removal) of the water quality volume, (0.3-year return events) while controlling the two-, 10-, and 100-year event discharges, described in the design summary in Table 5.10-1. The features to be addressed are access, maintenance and flow control.

There are many ways to provide water quality treatment and manage larger flows through the pond and outlet structure(s). Most stormwater-treatment ponds will require multiple outlet spillways to handle the water quality treatment as well as provide conveyance of larger flood flows. Weirs can be designed to provide the required low-flow characteristics and can be combined with overflow channels and overflow weir sections and/or culverts if needed for larger events. Some examples of weir outlet structures are shown below. One can use V-notch weirs, multiple orifices or pipe outlets to accomplish the same objectives. The optimum design should meet both the flood-control and water-quality-treatment objectives.

#### **Outlet Control Structures**

Outlet control designs consisting of V-notch weirs, multiple orifices and multiple-stage weirs are described by Pitt (1994a), USDA, SCS, (1988) and others. More information concerning outlet-design methodology can be obtained from the Minnesota Department of Transportation (MnDOT) or consulting engineers familiar with multiple flow-control issues.

#### **Outlet Features**

Outlets are usually built into a dike or berm with easy access for maintenance and where structure access is available. A box or manhole outlet structure can accommodate a variety of outlet control mechanisms. A skimming device to remove floatable materials and liquids is a desirable outlet feature. Skimmers should extend about 6 inches below the ordinary pool level, and flow velocity at the skimmer should be reduced to about 1 fps. Outlet trash racks may be needed as final outlet

protection and as a safety device. Trash racks should be designed so that debris will be lifted by higher flows. In addition, periodic maintenance will be necessary to remove trash and repair damage caused by natural forces or vandalism.

Box drop structures or manhole access control mechanisms often have accessible control gates equipped with locks. Interior weir control structures, including removable aluminum plates, stop logs and orifice outlets, are also recommended. Drawdown valves can be included if they are used and maintained. If not regularly operated and maintained, these valves often become virtually impossible to operate. Stand pipe outlets are not recommended unless accessible and heavily reinforced to prevent the damage from ice movement (see Figures 5.06-1 through 5.06-3).

### **Final Design**

Once the pond area and outflow rates have been established, the outlet needs to be designed and sized. The sizing of outlet structures is typically a process where iteration refines the design details. A stage discharge curve is usually established for a given outlet design, then a model is run to determine whether the peak outflow for the water quality volume and the two-, 10- and 100-year events is at or below the applicable criteria.

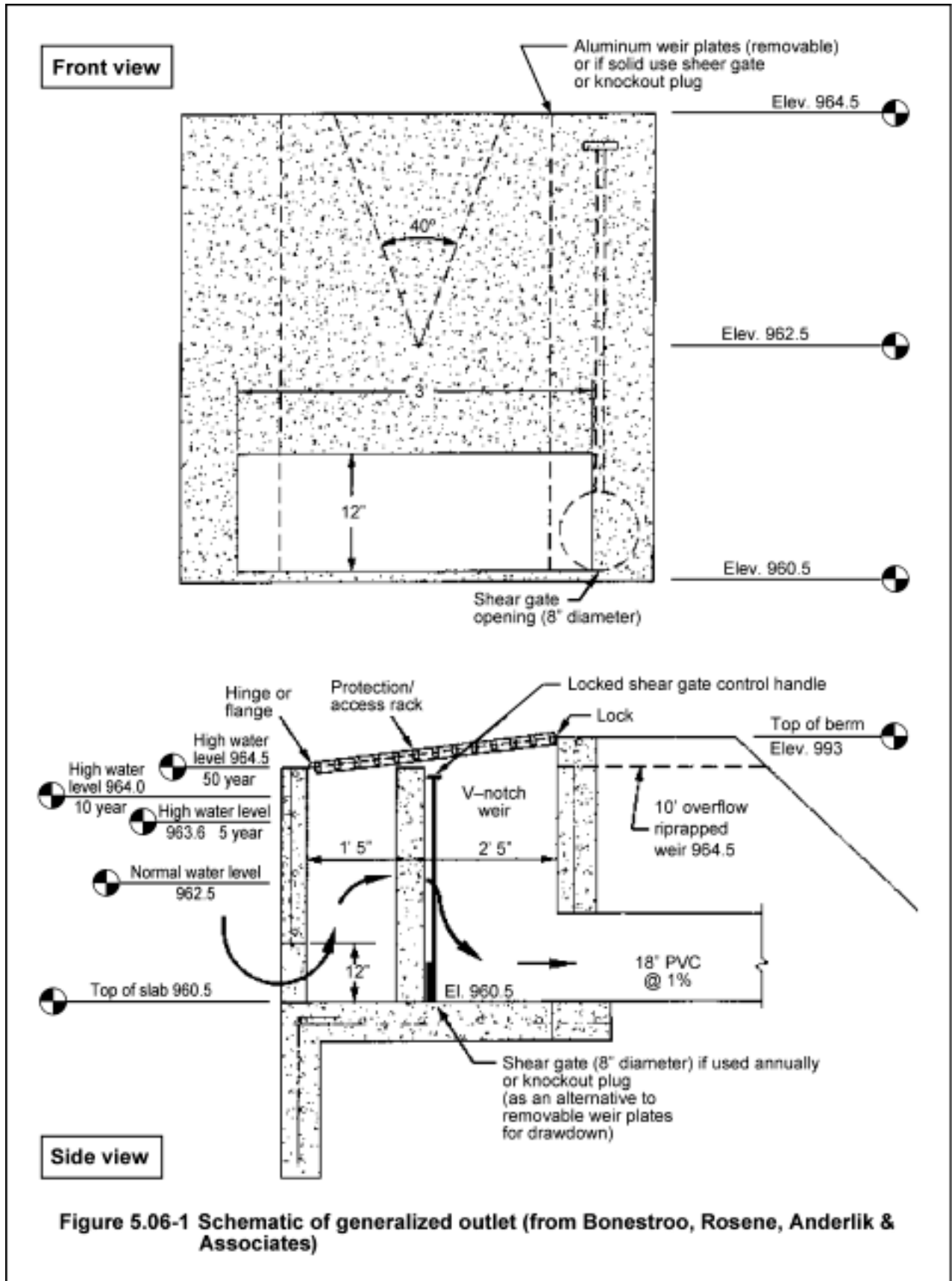

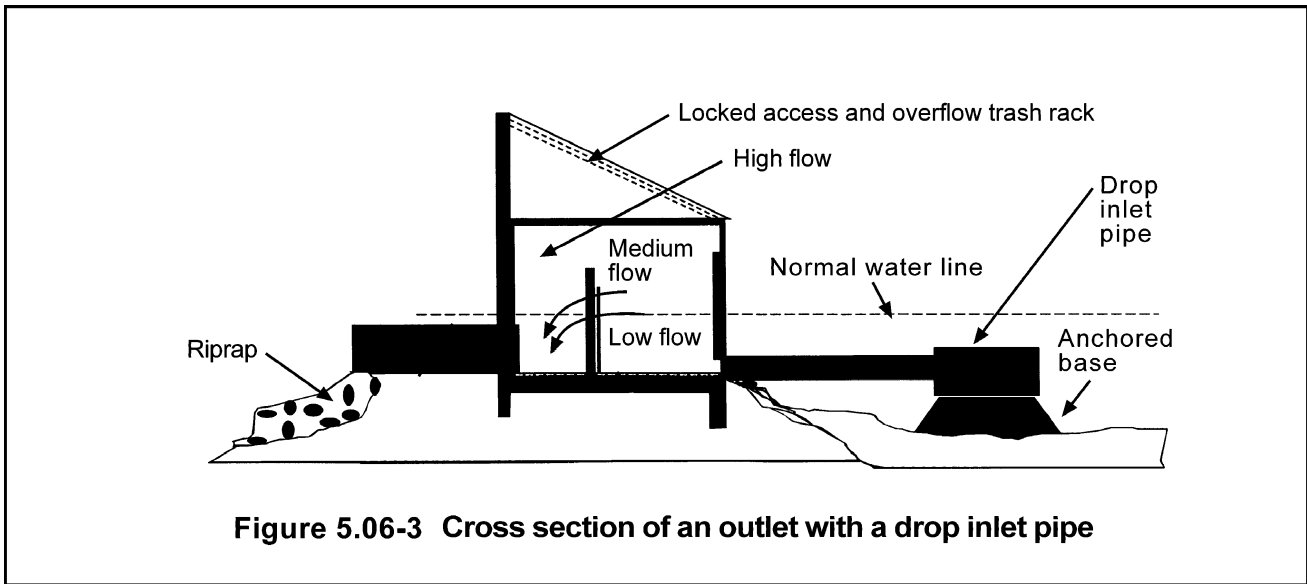
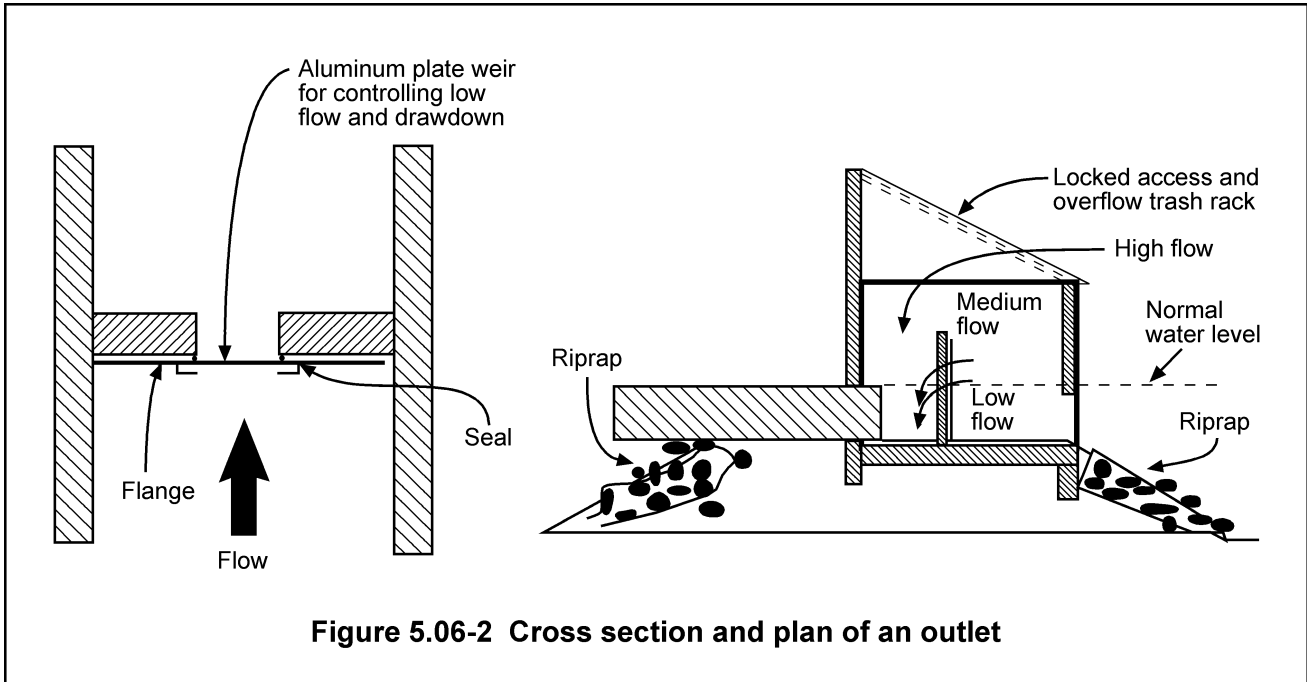

## **5.07 Pond Design Criteria: OPERATION AND MAINTENANCE**

### ***DESIGN AND CONSTRUCTION OF STRUCTURES***

All embankments, spillways and other structures for ponds should be constructed in accordance with accepted engineering practice, such as the NRCS Field Office Technical Guide, Standard 378, *Ponds*, (USDA, NRCS, February 1995), whenever applicable. Construction should be in accordance with appropriate construction and material specifications. Dam safety requirements should always be incorporated in the structural design. See section 5.70 for more information.

#### **Fences**

Most stormwater ponds do not require fencing and typically pose a safety hazard that is no greater than that of existing lakes and wetlands. This may not be the case when slopes are too steep, pond inlet flow velocities are large, or where an unexpectedly deep pond exists. Most natural water bodies in Minnesota are not fenced, even though they can pose a hazard. Similarly, most constructed ponds are not fenced. In fact, a fence can be a detriment because it may impede escape or rescue efforts. Typical regulatory requirements for ponds include four horizontal feet to one vertical foot (4:1) side slopes, or less, and vegetated benches. Ultimately, liability and decision-making rests with the local government, and decisions must be made on a site-specific basis.

#### **Sediment**

Sediment accumulation is usually the primary long-term-maintenance concern. Sediment accumulation may result in loss of pond volume or creation of channels that may cause short-circuiting of flow through the pond. Therefore, access to primary settling areas should be an integral part of any design.

#### **Erosion Control**

Permanent and temporary erosion-control measures are typically incorporated into the plans and specifications for a stormwater-treatment pond. Permanent erosion-control features include provision for a vegetative buffer strip around the pond, design of grassed waterways as overflow channels, armoring of spillways and banks, and any other permanent features needed to prevent erosion for the life of the facility.

Temporary erosion controls include items, such as straw bales, silt fence and mulch, that are applied or installed to prevent erosion until vegetation is again established in and adjacent to the new pond. Information regarding erosion control and landscaping is available from the NRCS and MnDOT and from consulting engineers.

If erosion should persist following construction, remedy the situation as soon as possible. Many new and standard treatments are available for this purpose, including application of erosion-control blankets and turf reinforcement mats. (See chapter 6).

## Erosion-protection Areas

Pond benches and adjacent upland areas may need to be stabilized following construction of the basin. Typically, a combination of permanent and temporary erosion-control measures are necessary. The desired erosion control, seeding work and other construction-site restoration are typically incorporated in the plans and specifications for the stormwater-treatment pond.

Erosion of banks, spillways, outfalls and channels should be the most immediate concern. These areas should be inspected frequently after construction and on a regular schedule thereafter. If erosion occurs, the eroded areas should be restored as quickly as possible. If erosion persists, the area should be protected with appropriate permanent measures, such as bioengineering measures, turf reinforcement mats, vegetated-concrete-block-armoring or properly sized riprap and filter materials.

Vegetated buffer strips (of about 25 ft) that surround a pond will help to prevent erosion and treat runoff entering the pond from the pond's immediate tributary area. The buffer may also serve as diverse habitat for wildlife, which, incidentally, helps to avoid undesirable monocultures, such as flocks of geese.

Information about landscaping pond sites and erosion control is available from the NRCS, from the Minnesota Department of Natural Resources (MDNR), the MnDOT and other professionals.

## Vegetation

Establishment of vegetation on site is a permanent erosion-control feature that helps to maintain the integrity of the pond and its appearance. Any vegetation to be established should be suitable for conditions that exist on site. Literature regarding this subject includes Eggers and Reed, 1997; Dindorf, 1993; Schueler, October 1992; and Henderson *et al.*, 1999. Establishment of a vegetative buffer strip around the pond is strongly encouraged to prevent erosion, provide wildlife habitat, impede human encroachment, and to provide a more aesthetically pleasing facility.

**High marsh** and **low marsh** vegetation around and in the pond is generally encouraged. It prevents erosion, stabilizes the bottom sediments, and provides physical and biological treatment. Establish appropriate vegetation, chosen to thrive based on frequency and duration of inundation within the treatment system. Use the guidance of Schueler (October 1992) for general design, and information in local literature (Eggers and Reed, 1997; Dindorf, 1993; and Henderson *et al.*, 1999) or other professionals for appropriate local modifications.

Any vegetation to be established on site should be suitable for natural conditions. In many cases, the existing plant species will inhabit the bench area from natural seedbeds and it will be unnecessary to provide other plant material. However, in some cases, landscaping measures, such as wetland soils, plantings and additional contouring, may be desirable or necessary additions to the project.

Vegetative harvesting may be considered for stormwater-treatment ponds to remove nutrients contained in the vegetation. Such ponds should be designed to allow access for harvesting. Proper disposal of cuttings should be required.

## **5.08 Pond Design Criteria: SPECIAL CONSIDERATIONS**

### **Water-quality Standards**

Water-quality standards must be maintained for all waters, even if no specific permit is required for a particular action. The primary requirements are that waters not be degraded by human activity in such a way that the existing beneficial uses of the water are lost.

The generation of new surface-water runoff is not prohibited. The question that needs to be addressed is, does the human activity (usually development of land in urban areas) change the uses or degrade the receiving waters? If water-quality standards are violated, an individual permit or enforcement action may be required to remedy the violation. If unique resources, such as trout streams, ground-water-recharge areas or wetlands exist, they must be adequately addressed in the plan.

### **Ground-water Pollution**

Whereas infiltration through 3 ft of natural soil is usually sufficient to treat most storm water, ground-water contamination is a potential problem where there is a direct path for infiltration, such as highly permeable soils or karst topography. In addition, site-specific sources, such as potential spills or industrial contaminants, having potential for discharging pollutants to ground water, may require additional considerations or involve certain prohibitions. Local governmental units should impose restrictions on wellhead-protection areas. Stormwater discharge to ground water, without adequate treatment, is prohibited by state laws.

### **Pollutants in Sediments**

In addition to the physical sedimentation process, pollutants associated with urban runoff, such as trace metals, will accumulate in sediments. For example, when U.S. Fish and Wildlife Service sampled bottom sediments in the Minnesota Valley Wildlife Refuge below a major stormwater discharge point in the Twin-Cities area, it found lead levels in the sediment exceeded 300 parts per million (ppm). Tissue analysis of bottom-feeding fish showed whole-body lead levels in excess of 3 ppm (U.S. Fish and Wildlife Service, 1988). This indicates probable biological uptake of the metals in fish. The effects of trace metals on waterfowl and plant tissue have also been shown to be harmful at higher levels. Therefore, there is always a concern wherever there is a potential for concentration or bioaccumulation.

### **Sediment Removal**

Pond sediments must be removed and disposed of in accordance with the sediment-disposal guidance (see chapter 7, part 7.28). To date, sediments in stormwater ponds have not been found to exceed hazardous-waste criteria. However, if a stormwater pond is affected by spills, hazardous waste or runoff from industrial areas, then source separation and/or controls, monitoring and other special precautions may be needed.

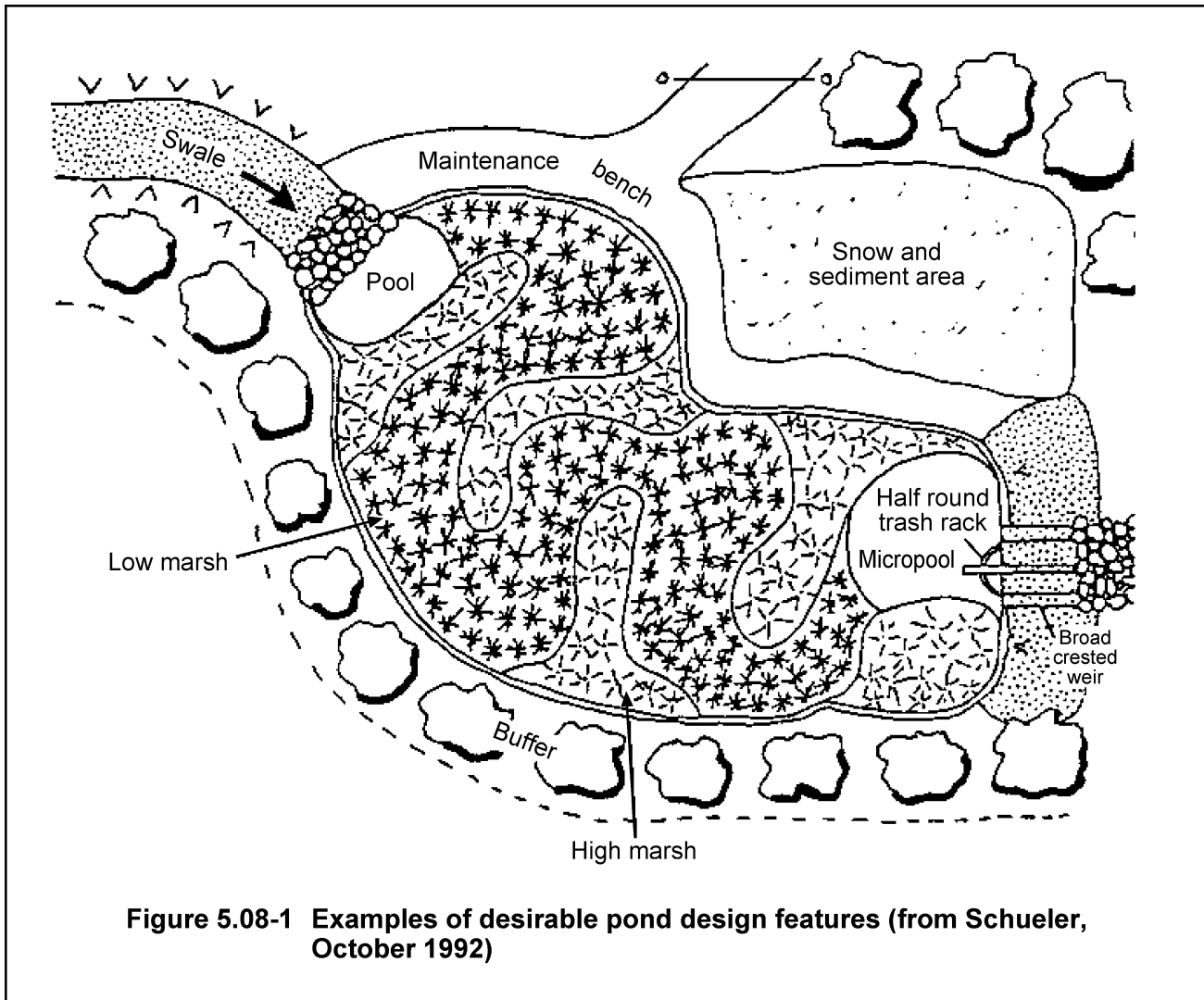

**Figure 5.08-1 Examples of desirable pond design features (from Schueler, October 1992)**

### Permitting Requirements

The design team must investigate the nature and scope of local, state and federal permits and approvals that must be secured. These may include:

- Clean Water Act, Section 402 storm water National Pollutant Discharge Elimination System (NPDES)/State Disposal System (SDS) permit for significant point source, construction activity or industrial sites (from the MPCA).
- Clean Water Act, Section 404 permit if the treatment system involves the placement of dredged or fill material in waters of the United States, including wetlands, lakes or streams (from the U.S. Army Corps of Engineers).
- Clean Water Act, Section 401 water-quality certification if any federal permit is required (from the MPCA).

- Local or state permits for such things as wetlands, storm water, sediment control, dam safety, waterway disturbance, and forest clearing (from the MDNR, MPCA and local governments).

The design team should objectively assess the “permitability” of the project, and strive to involve key members of the regulatory community early in the planning process.

### **Dam Safety Requirements**

In accordance with state rules, a permit from the Minnesota Department of Natural Resources (MDNR) is required for the construction of any dam or artificial barrier that is over 6 ft high and has a maximum storage capacity over 15 acre ft. The height is measured from the top of the dike or overflow (not the spillway structure) to the downstream toe of the dike. Structures up to 25 ft high and with a storage capacity up to 50 acre ft may be exempt from this permit requirement if it is proven that there is no potential for loss of life due to failure or misoperation.

### **Wetland Impacts**

Wetlands may be impacted by the diversion or discharge of storm water as well as the discharge of fill. The regulatory agencies involved include the MPCA, MDNR, the Corps and local governmental units (LGUs), including those that implement the Wetland Conservation Act. To determine whether a project will impact a wetland, the appropriate regulatory body should be contacted. In addition the guidance, such as *Storm Water and Wetlands: Planning and Evaluation Guidelines for Addressing Potential Impacts of Urban Storm Water and Snow-Melt Runoff on Wetlands* (Minnesota, State of, Storm Water Advisory Group, June 1997), should be consulted.

The wetland vegetation types as well as the hydrologic changes, such as the discharge to the wetland, should be considered. *Storm Water and Wetlands* (Minnesota, State of, June 1997) indicates that sensitive wetlands, such as calcareous fens, should retain their hydrologic regime to avoid impacting the wetland. On the other hand, less-sensitive wetlands can accommodate moderate-to-substantial changes of hydraulic and pollutant loading. At the heart of the planning considerations should be avoiding, minimizing, and mitigating the destruction or changes in wetland values from hydraulic alterations.

### **Natural Wetlands**

Natural wetlands are not recommended for use as treatment systems without pretreatment of urban runoff. Wetlands can be very effective for trapping and treating urban pollutants. However, excessive urban runoff can overload and degrade a natural wetland. The solids in urban runoff are deposited in the wetland, where they may be difficult to remove at a later date. Hydrologic changes in the frequency and duration of inundation can affect any wetland vegetation and wildlife habitat, but some types can be affected significantly more than others. Because of these factors, and the potential damage to wetlands from increased urban runoff, it is strongly recommended that appropriate pretreatment be used. Ponding to remove sediments and nutrients, or ponding, flow splitting and other flow controls to prevent destructive hydrologic changes are some of the recommended measures.

Natural wetlands can serve to “polish” runoff after it has been treated by a BMP, such as a treatment pond. The wetland can provide some additional removal of fine sediment and allow nutrient uptake by plants. Care should be taken to limit the frequency and duration of inundation to levels appropriate to the sensitivity of the vegetation.

### **Wetland Conversion**

The decision-maker should compare the effectiveness of the pond to the effectiveness of the existing wetland system for the treatment of urban runoff. In order to compare these two, the wetland can be monitored to evaluate the removal efficiencies that are currently being obtained. But, several years of monitoring may be required to obtain representative data. An alternative to monitoring involves utilizing available literature and models to provide a range of probable values. If the pond system is modeled, the variability of the model should be recognized. Expected ranges of pond and wetland performance should be analyzed as part of the project-development process.

The variability of flow rate and pollutant loading should also be discussed. The treatment efficiency of natural and constructed treatment systems will vary greatly no matter how well a system is designed.

Generally, it is better to build a treatment pond in an upland area than to alter a natural wetland. Unless unavoidable circumstances can be demonstrated, significant alteration of natural wetlands should be avoided.

Further compensatory mitigation may be required to offset the loss of wetland area values or functions that can be attributed to the conversion of existing wetland to a wetland altered to provide additional treatment for storm water.

### **Constructed Wetlands**

The design of constructed wetlands for treatment is described in Schueler (October 1992). Seven basic design criteria related to volume, area, depth allocation, volume allocation, length, dry- and wet-weather water balance, and extended detention volume are listed. The establishment of proper vegetation is essentially determined by these basic parameters. Care should be taken to adapt the vegetation to local conditions rather than using guidance directly. For example, Schueler’s vegetation lists are developed for the Mid-Atlantic Region. Minnesota’s vegetation design parameters vary considerably across the state from north to south and from east to west because of climatic differences, such as temperature and hydrology. There are also significant geologic and soil differences from place to place throughout Minnesota; which can significantly affect the acceptability of a particular wetland design.

Local professional sources of information on vegetation and plantings should be consulted for all projects. Helpful sources include the MDNR and MnDOT Environmental Services as well as some of the cited literature, such as Eggers and Reed, 1997; Dindorf, 1994; and Henderson *et al.*, 1999.

## **Wetland Replacement**

Replacement of lost wetlands is necessary to satisfy the federal and state laws, rules and policies of no net loss of wetlands. Created stormwater-management basins are generally not considered to be wetland mitigation. Constructed wetlands, stormwater ponds, and water-quality-treatment ponds may be eligible for water quality replacement credit, provided appropriate design criteria are met. The eligibility and design criteria should be determined by the jurisdictional regulatory agencies, which may vary depending on the location and nature of the project. Be careful that the values of the area to be used as mitigation are not greater than the pond they are suppose to mitigate, which may be the case if a forest or woodland is used to create a wetland-replacement area.

## **Other Regulations**

Any work within, or manipulation of, natural wetlands may be subject to state and/or federal regulations. Contact the MDNR for protected waters permit requirements, or the Board of Water and Soil Resources (BWSR) for the local unit of government delegated to implement the Wetland Conservation Act in a particular area. Contact the U.S. Army Corps of Engineers Regulatory Functions Branch for information on federal regulations and permits.

## **Design for Small Watersheds**

Watersheds under 100 acres in size may require special considerations. The flow from these small watersheds will be less consistent and more variable than that from large watersheds of the same type due to multiple hydrologic inputs and longer times of concentration in the large watersheds. Schueler (October 1992) states that wetland designs require an upland drainage area of at least 25 acres to be fully effective. Some local consultants (Klein, 1996) feel that wet ponds above the ground-water table should not generally be attempted for watershed areas of less than five acres since these ponds may tend to dry down to mud flats during dry periods.

Watershed areas of less than 20 acres may not produce enough runoff annually to maintain a wet pond unless the pond is deep enough to extend beneath the water table. If preliminary hydrologic design computations indicate that the watershed is unable to provide enough runoff to support a wet pond, then other BMPs, such as swales (Claytor, 1996) or modified dry ponds (Klein, 1996), should be evaluated. If the MPCA permit requirements cannot be met, contact the MPCA.

On any small watershed, a careful design process should be undertaken considering the following factors:

- rainfall frequency distribution;
- surface flow volume and other hydrologic conditions;
- ground-water levels and flow patterns;
- regulatory requirements and
- feasible alternatives.

## **Design for Winter-runoff Conditions**

Snowmelt runoff events in Minnesota may convey high concentrations of urban runoff pollutants to stormwater ponds and other receiving waters (Oberts, 1991). Recommendations to manage this potential influx of contaminated snow and ice melt include incorporating extended detention in the pond design, installing grass swales in the drainage system ahead of stormwater ponds, and storing contaminated snow and ice where debris and petroleum products are less likely to be transported to the pond (Oberts, 1991).

Water often flows over the ice in stormwater ponds during spring thaw, and may carry sediment directly out of the pond outlet. If this is a concern for a particular pond design, it is generally a good idea to expand the extended-detention capability of the pond. You can also increase the depth of the pond below the water quality spillway, thus allowing more room for the ice to collapse into the pond. If the pond is located in an area with a high water table, it may not be feasible to make this design modification.

Standpipe outlets may be destroyed by ice movement in winter. Standpipes are not recommended unless they are designed to withstand ice movement.

Following the recommendations of this chapter, by providing deep inlet and outlet zones or multiple pools, will usually result in designs that are generally robust enough to handle the winter and spring conditions without special considerations. However, runoff volume from snowmelt events can be very large, often the largest-volume event of the year. Ponds designed to function effectively in summer are often disrupted by winter and spring events. Inspection and maintenance during spring runoff should be a consistent feature of stormwater-treatment systems in cold climates.

In Minnesota's urban areas, snow piles are often created in parking lots, along streets and elsewhere. Store snow where debris oil and other materials cannot readily enter waters of the state. Discharge of such materials directly to waters of the state is prohibited. So, plan snow-storage areas that minimize surface-water impacts.

## **Dry-weather Flows**

Dry-weather flows should be sufficient to maintain the nature of the pond. Some considerations include having a watershed which should be large enough (at least 25 acres depending on soil type and rainfall) to sustain a wet, open-water pond. Maintaining permeable surface in the watershed to preserve ground water interflow should also be a priority.

When a wet detention pond is desired, soils on the proposed pond site should have an infiltration rate low enough so that base flow or stormwater runoff can maintain a permanent pool. Many natural soils contain hydrophytic plant propagules, which can be expected to grow in the new system. If these soils are not available, most other soils will allow the establishment of wetland vegetation as long as there is sufficient hydrologic conditions. Contact experts in this field for site-specific evaluation.

## 5.10 STORMWATER POND SYSTEMS

**Table 5.10-1 Treatment system summary design matrix: recommended criteria**

Design Parameter	Design Basis	Planning Basis	Design Calculations
Total pond area	Overflow rate and water quality and quantity control volume	0.5-3.0% of watershed, based on ultimate land use runoff	0.5 to 3.0% of watershed, depending on land use
Benches around edge of pond	Vegetated area for erosion and access control	10:1 slope around pond edge (10-ft width desirable)	Bench area = pond perimeter x 10 ft
Pond inlet zone (3- to 8-ft-deep pool)	Prevent scour and control mixing in treatment areas	10-20% of area and volume	Reduce velocities from inlet zone to <1 fps
Pond outlet zone (3- to 8-ft-deep pool)	Prevent scour	Outlet 10-20% of area and volume	Maximum velocity in pond <2 fps (1-yr. storm)
Main treatment zone			
Deep water: (3 to 8 ft) depth treatment area	Maximum quiescent settling and minimize resuspension velocities	20-40% of area 20-70% of volume	Area and volume calculation (for treating 2.5 in runoff volume)
Low marsh (6-18 inch) treatment zone	Emergent vegetation for settling and biological treatment	25-40% of area 30-55% of volume	Area and volume calculation
High marsh (0-6 inch) treatment zone	20% reserved for pond bench; remainder for biotreatment areas	30-80% of area 10-25% of volume	Area and volume calculation
Semi-wet or extended detention (0-3 ft above the outlet) treatment	All in pond fringe and around high areas for multipurpose design	0-50% of area 0-50% of volume	Stage discharge relation, <5.66 cfs per acre of pond for water quality volume
0.3-yr., 1.25-inch event* (instant runoff volume)	Water quality volume	Quantity out ÷ pond surface area in acres < 5.66 cfs	Outflow rate
1-yr., 2.4-inch event*	Scour prevention	Maximum velocity in treatment area ≤ 1 fps	Q out/area of critical cross section
2-yr., 2.8-inch event*	Scour prevention	” ≤ 3 fps	”
10-yr., 4.0-inch event*	Scour prevention	” ≤ 5 fps	”
100-yr., 6.0-inch event*	Scour prevention	” ≤ 5 fps	”
Discharges to erodible channels or streams (postdevelopment)	Erosion and flood control	One-half the 2-yr. and same as the 10- and 100-yr. predevelopment rates	Pre-existing runoff vs. pond discharge at full development
Discharges to wetlands	Wetland vegetation type	Bounce and duration for vegetation type	Follow wetland guidance

\* 24-hour NRCS distribution events.

## 5.11 Pond Systems: ON-SITE VERSUS REGIONAL PONDS

On-site detention uses structures to detain runoff on the development site. These types of structures often integrate parking lot, rooftop and cistern storage; dry or wet detention ponds; infiltration basins and infiltration trenches.

On-site structures are generally satisfactory for reducing peak discharges for a certain distance downstream of the site. Infiltration structures are also capable of reducing runoff volumes. However, random placement of on-site detention facilities for stormwater detention can actually increase flooding downstream (Pitt, 1998). When this is a potential problem, a peak-flow timing analysis of the watershed should be performed as part of the pond design planning process.

From a water-quality standpoint, the benefit of these structures can vary widely. As previously mentioned, the effectiveness of dry or wet detention areas depends upon their design. Infiltration basins or trenches can be very effective for reducing pollutant loadings to surface water from a site. However, these must be carefully designed and maintained to prevent contamination of ground water and to ensure that they continue to function.

Maintenance is a major drawback to the use of on-site facilities for trapping pollutants. Regular maintenance is critical to the continued performance of most structures for pollutant removal. The large-scale use of on-site facilities can result in hundreds of these structures in an area, with individual landowners responsible for maintenance. This results in a maintenance workload that can be difficult to manage.

Regional detention ponds with larger drainage areas are generally more cost effective than on-site basins. Regional detention ponds have several other advantages. One is that regional detention ponds can sometimes provide cost-effective control for already developed areas as well as for new development. This is an important consideration when nonpoint-source pollution from previously developed areas must be controlled to meet water-quality goals. In many cases, on-site detention in previously developed areas would be prohibitively expensive. Studies have concluded that random placement of detention facilities in a watershed may have little effect on overall peak flows and can actually increase downstream problems (Pitt, 1998). Because of this, on-site basins may not reduce peak flows enough to control flooding and streambank erosion.

Regional ponds have some disadvantages. One is that regional ponds may leave some areas unprotected if treatment is not provided between the development and the waterway. The drainage area of regional ponds should be small enough to minimize unprotected areas, but large enough to allow cost savings and meet overall stormwater-management goals.

Another disadvantage to regional ponds is that site constraints may limit the area available to construct a properly sized pond. Available land area may be limited or there may be wetlands or other resources at the site that would be impacted. Often in developed or rapidly developing areas, the only remaining undeveloped areas that have possible sites for effective water-quality treatment are the low areas, such as wetlands, or areas adjacent to them.

## 5.12 Pond Systems: ON-LINE VERSUS OFF-LINE PONDS

### On-line (On-channel) Storage

On-line or on-channel storage involves constructing an embankment, widening the channel or other means to hold water in a swale, valley or similar area. This allows a detention facility to control runoff from an entire drainage area. When properly designed, these structures can be some of the more effective practices available for trapping pollutants from urban areas as well as for flood control.

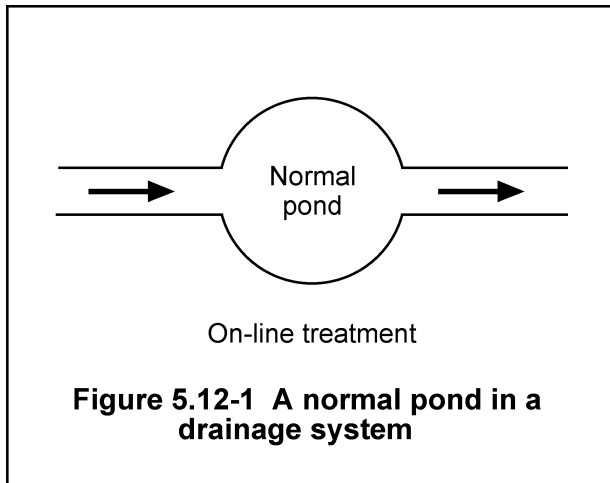

The primary process involved in pollutant removal with on-channel storage is settling of solid particles. However, detention ponds can also be designed to take advantage of biological uptake to remove dissolved nutrients. The design considerations and effectiveness of on-channel detention for pollutant removal is discussed in the extended-detention basin and detention pond practices.

On-channel storage can also be effective for flood control. In many areas, flood control is subject to regulation of the local watershed district or water-management organization.

Local needs for flood control can vary widely, depending upon drainage conditions. In many cases, regional detention facilities are most effective for overall flood control and are also the most economical form of detention for water-quality treatment. To minimize the amount of unprotected area and maximize the economies of scale, the drainage area of a regional facility should be on the order of several hundred acres (Hartigan, 1986). Larger structures may require a dam safety permit,

but all structures should be designed with safety in mind since they can create downstream hazards because of the impounded water. This is especially important in a densely populated urban area.

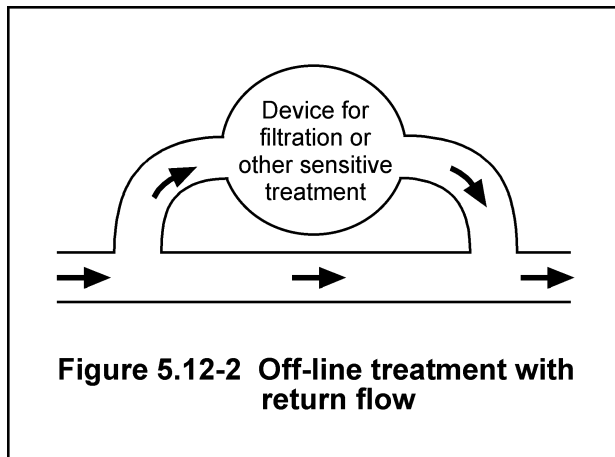

Stormwater-detention areas that receive flow that is diverted into them are referred to as "off-channel storage." These structures can only treat flows that are diverted to them; flows that are bypassed typically receive minimal water-quality treatment. Off-line treatment can also be used to reduce peak discharges to downstream areas.

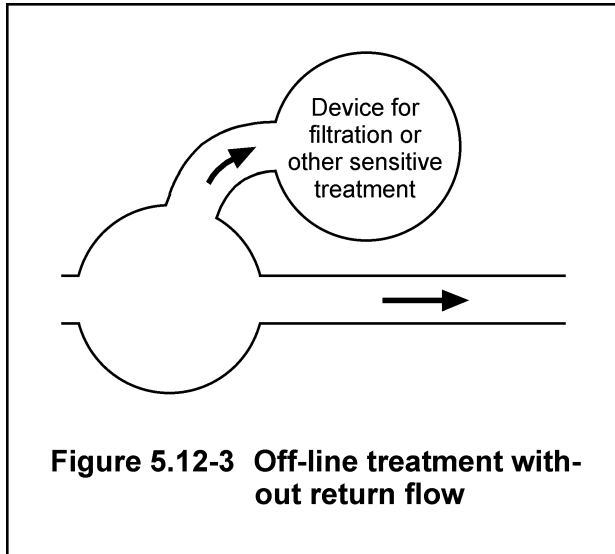

Although off-channel storage can reduce peak flows and trap pollutants, the two uses are not totally compatible. For pollutant removal, the best use of the storage is to treat all flow from small, frequent runoff events. However, treating small events may use up all or much of the off-channel storage volume before peak discharges from a large storm arrive.

To maximize peak-flow reductions, an off-channel storage facility is often designed to bypass low flows. During high flows, a portion of the discharge is diverted into the storage area, thus reducing peak flows. The problem with this is that runoff from small events is not treated. Unfortunately, these

small runoff events deliver a majority of the annual runoff volume (Pitt, 1998).

Figure 5.12-3 provides one solution for the water-quality aspects of this problem. An on-line pond can provide pretreatment and divert low-flow events for further treatment, such as infiltration. This can be highly effective for low flows, while treating high flows to a lesser degree.

### 5.13 Pond Systems: OTHER POND SYSTEMS

Other pond systems can be used, but each has advantages and disadvantages for a given purpose and situation.

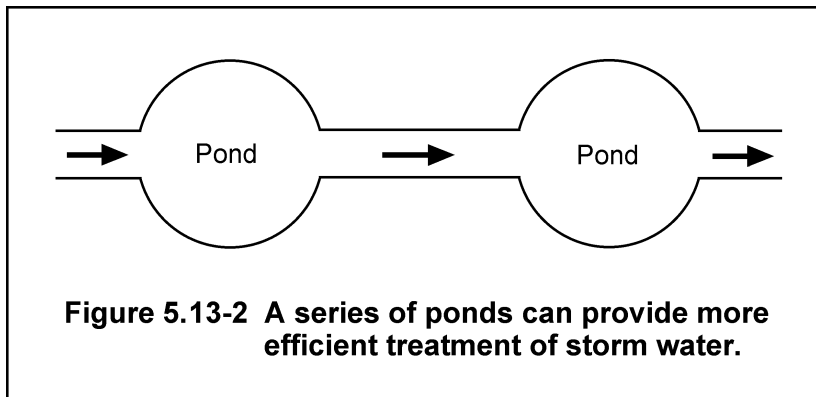
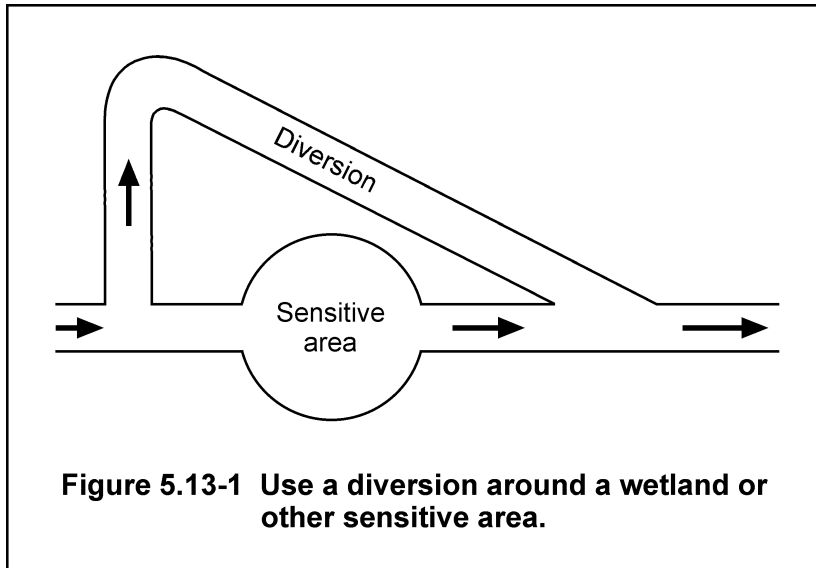

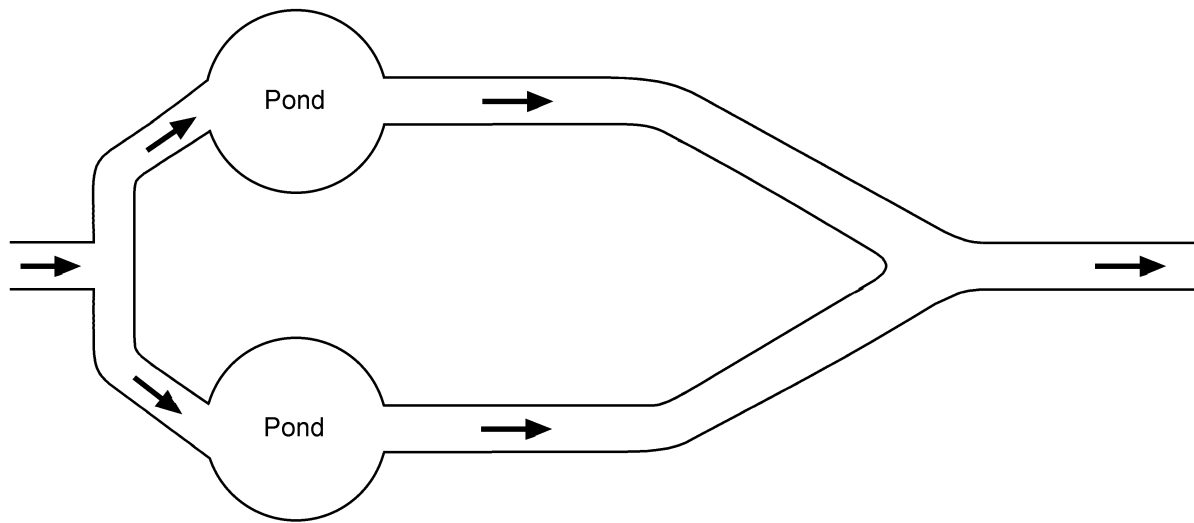

**Figure 5.13-3 Parallel ponds allow continued treatment of storm water during pond maintenance.**

## 5.20 Ponds: EXTENDED-DETENTION PONDS

### *DESCRIPTION AND PURPOSE*

Across the country, terms such as “retention” and “detention” have variable and inconsistent meanings (Walesh, 1989). In this manual, extended-detention basins are stormwater basins that are designed to temporarily hold storm water for an extended time, which varies with the stormwater-runoff volume. Extended detention allows particulate material and debris to settle out of the water column while drawing the pond down for additional storm-event storage. Ponds that use this method can be dry, designed with a shallow marsh or have a permanent pool. Figures 5.05-1 and 5.20-2 show how the features of extended detention can be incorporated in very different types of ponds.

All ponds have some aspects of detention, but in this manual, “extended detention” describes ponds that are not just flood-control measures, but are designed to use this detention time as their primary method to allow the physical settling of pollutants.

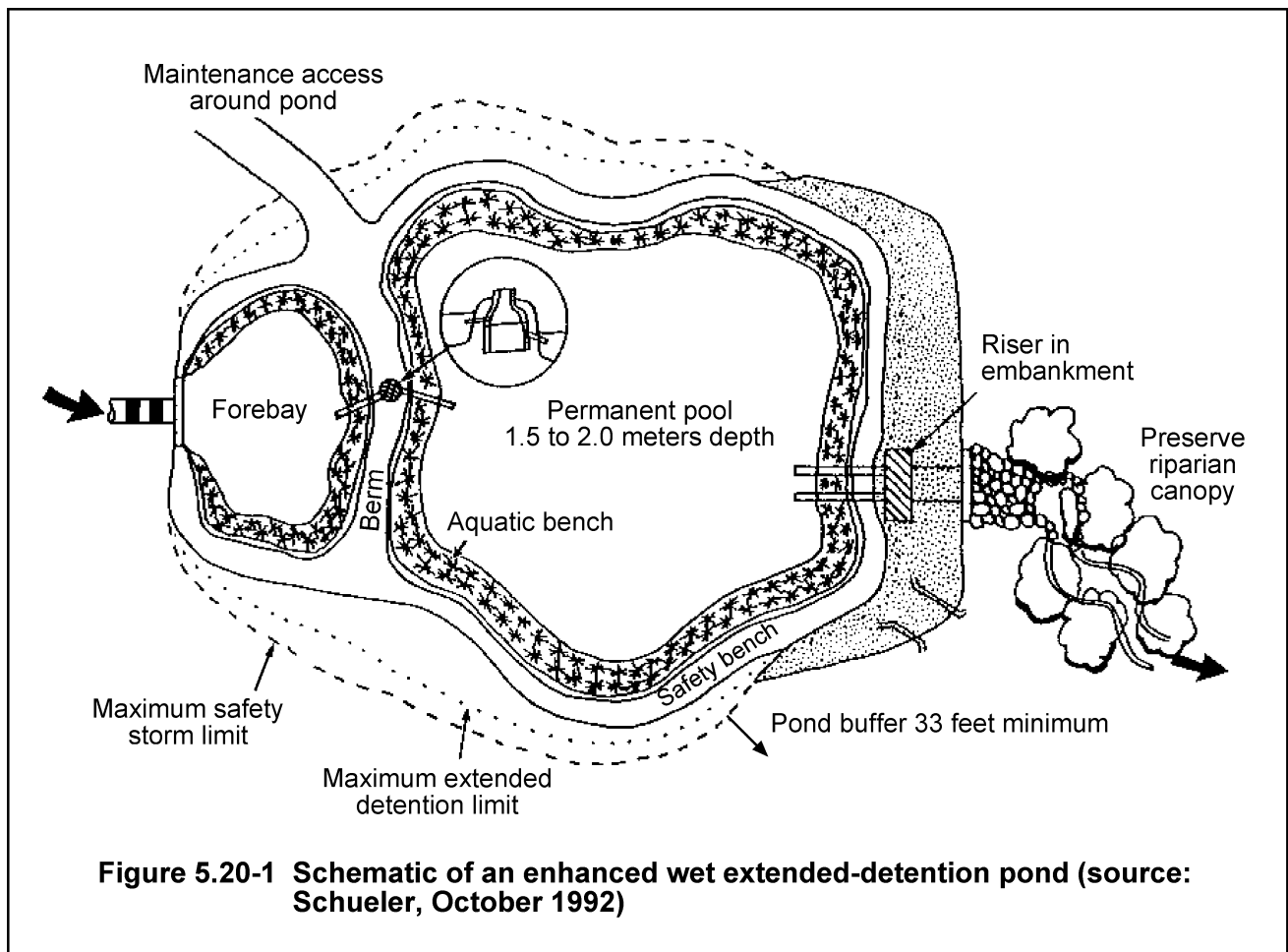

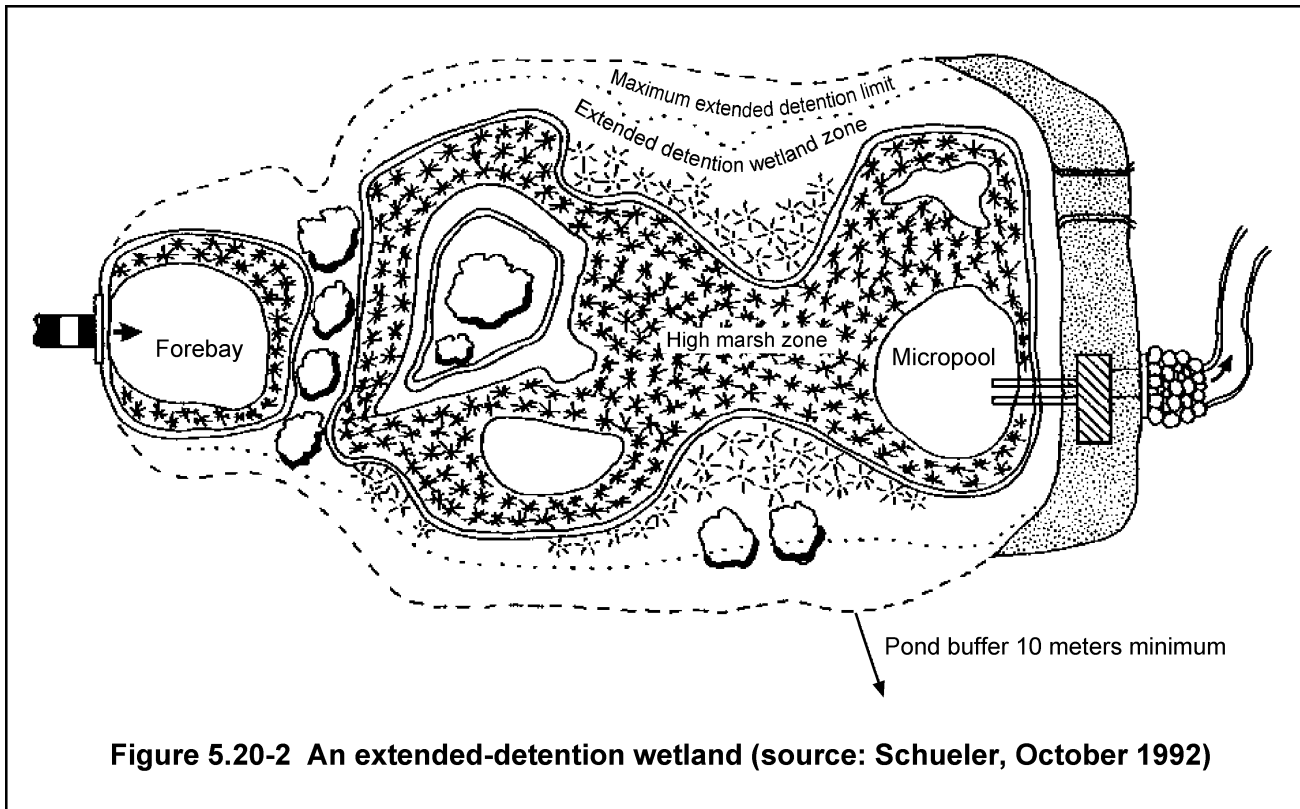

Extended-detention ponds are effective for removing particulate pollutants from urban runoff as well as reducing peak discharges. In many instances, dry ponds designed as flood-control structures can be modified to meet the criteria of an extended-detention pond for a relatively low initial cost but generally increased maintenance costs.

### **TARGET POLLUTANTS**

Sediment and the associated pollutants, such as trace metals and nutrients, are the pollutants most effectively controlled by extended-detention basins. If the outlet is designed as a skimmer, floating debris and organic matter can also be effectively trapped. If a permanent pool or shallow marsh area is included in the design, some removal of fine sediment and soluble nutrients can be achieved. Extended-detention basins are also some of the best facilities for treating spring and winter runoff, because of how ice conditions effect the flows. Ponds without extended detention have minimal storage above the ice surface; therefore, treatment is often bypassed. In addition, extended-detention basins are very effective for controlling peak discharges, an important factor in reducing downstream streambank erosion and sediment loads.

## ***EFFECTIVENESS***

Extended-detention basins can be fairly effective for removing particulate pollutants from urban runoff. The efficiency of an extended-detention basin depends largely upon the surface overflow rate (Barfield *et al.*, 1986).

The primary treatment process for most basins is that of settling. Pollutants attached to sediment particles exhibit settling characteristics similar to those of sediment. Lead, for example, has a strong affinity for sediment and its removal curve is very similar to that of sediment. Zinc, on the other hand, has a substantial portion of its load in the soluble form. Almost all of the zinc that is removed by extended detention is the portion that is attached to sediment.

Phosphorus acts similarly to zinc in that slightly less than half of the phosphorus is dissolved and is not removed through sedimentation. Nitrogen has an even lower removal rate because of the high percentage that is typically in a soluble form. If additional removal of nutrients is desired, several alternative designs can be used. For example, the permanent pool of the extended-detention pond can be designed and managed as a wetland treatment system or deep pond. Biological and chemical transformations in the pool and wetland can provide some removal of soluble nutrients between events. The permanent pool of water in the marsh will also provide a much higher removal efficiency of suspended solids for very small runoff events by providing a relatively long residence time between storms for settling.

## ***PLANNING CONSIDERATIONS***

Extended detention is a practical way to derive water-quality benefits from dry stormwater-detention basins that were originally designed and constructed for flood control only. In many cases, the outlet structures of these dry basins can be modified to detain runoff from small storms long enough to remove many pollutants.

When designing new facilities, extended detention is a possible alternative when a limited permanent pool of water is desired because of site constraints or because of concerns, such as the warming of sensitive trout streams. The temporarily flooded areas of extended-detention basins may be suitable for some recreational activities if they are maintained in a normally dry condition.

The lower stage of extended-detention ponds can be designed to be managed in one of several ways. The lower stage can either be normally dry (Figure 5.05-1), have a permanent pool of water (Figure 5.20-1) or have a shallow marsh established in it (Figure 5.20-2). Those with a shallow marsh or permanent pool of water typically will be more effective for pollutant removal than those that are normally dry. This is because they will provide sediment storage and allow quiescent settling to occur.

Detention time is widely used, but problems are encountered in defining detention time in the case of intermittent stormwater flows. It is essentially impossible to define a detention time for stormwater flows (USEPA, 1983, NURP, Vol. II, 1982). Overflow rate which is equivalent to outflow rate, is the design parameter recommended for extended-detention-pond design (Barfield *et al.*, 1986).

When designing an extended-detention pond, it's important to recognize that small storms (typically less than 1.25-inch events or 0.3-year-return-frequency events) that produce less than 0.5 inch of runoff) deliver the majority of the pollutants throughout an average year (Pitt, 1994 and 1998). If small storms are not considered in the design, their effects may not be adequately treated.

## ***DESIGN CONSIDERATIONS***

The minimum recommended water quality volume for extended detention is the total volume of runoff from a 1.25-inch event (a storm with a return frequency of once in about 0.3 years). This should be calculated as an instant runoff volume. Other regulatory programs often require treatment of the “first flush” runoff volume. First flush treatment is an often-used concept for water quality volume. In some urban areas, the water quality volume is often considered as 0.5 inch of runoff for all impervious areas in the watershed. If you are required to meet other regulatory requirements, we recommend calculating both the 1.25-inch and other regulatory volumes, then using the larger measure for the water quality volume in your design.

### **Outflow Rate**

The design detention time can be achieved by adjusting the outflow rate from the basin. As the outflow rate is decreased, the detention time and the required temporary storage volume will be increased. The outlet device can then be designed to provide the desired outflow rate of 5.66 cfs per acre of pond surface area for the water quality volume (Pitt, 1994a and 1998) and appropriate rates for the two-, 10- and 100-year events.

For extended-detention basins, a multiple-stage outlet design is usually needed to provide extended detention of small (less than two-year event) storms while allowing a higher discharge rate for larger storms passing through the basin. This keeps the storage volume down to a reasonable level.

### **Outlet Device**

The outlet device of an extended detention pond must be effective at controlling the outflow rate while also being protected from clogging.

The type of outlet device used will depend upon factors, such as the type of principal spillway, pond configuration and extended detention outflow rate. For very low outflow rates, internal orifices or subsurface drains may provide adequate control of the outflow rate. However, on structures with larger drainage areas, orifices that can pass a substantial flow may be required.

### **Sediment Storage**

Adequate sediment storage should be provided, usually to hold five to 25 years of sediment accumulation. A forebay at the inlet to the sediment basin can be used to trap coarse sediments, such as road sand, and large debris, such as leaves and branches. If sediment is removed from the forebay or the entire basin on a more frequent basis, the sediment storage volume in the basin may be reduced. A common maintenance cycle would be about five years.

## **Pond Shape**

The pond shape should be selected keeping several considerations in mind. First of all, the pond should be designed in such a way that turbulence in the main treatment area is minimized. Forebays are the most commonly recommended method of turbulence reduction. Reducing the turbulence will reduce the chance that previously deposited materials will be resuspended. It will also result in conditions more conducive to settling while the pond is filling.

Second, the inlet and outlet should be positioned in such a way that short-circuiting in the basin is minimized. Pond geometry that reduces short-circuiting is discussed part 5.02, *Pond Layout and Size*.

Third, the slopes in the basin should be flat enough that they are relatively easy to maintain. Slopes of 4:1 (horizontal:vertical) or flatter are recommended. In some cases, slopes flatter than 4:1 may be required because of soil-mechanics considerations. Accessible slopes leading into the basin should not be steeper than 3:1.

## **Low-flow Channels**

Low-flow channels provide additional detention and longer travel time to the outlet. The channel should not be extended near the outlet device. If the low-flow channel is allowed to extend to the outlet device, pollutants will be delivered directly to the outlet, and previously settled material then can be resuspended. A micropool is recommended at all outlets (Schueler, 1992).

## ***STRUCTURAL DESIGN AND CONSTRUCTION***

Any embankment, principal spillway or emergency spillway constructed in conjunction with an extended-detention basin should meet the criteria of NRCS Standard 378, *Ponds*, (NRCS, February 1995), wherever applicable. MDNR Dam safety program requirements must be complied with.

## ***MAINTENANCE***

There are considerations that can be used in extended-detention-basin design that will help reduce operation and maintenance costs. Some of these may not increase construction costs significantly, but can make maintenance easier.

1. Keep all slopes 4:1 or flatter whenever possible for safety and so that vegetation can be maintained easily.
2. All extended-detention outlet devices should be protected from clogging. All devices should have above-ground access for cleanout, should this be necessary.
3. Vehicle access to the pond at least 10 ft wide and no steeper than 15% should be provided. The planned maintenance access should never include travel on an emergency spillway unless the spillway has been designed for vehicles.
4. On-site sediment-disposal sites should be provided whenever possible. The cost of sediment cleanout increases drastically when sediment must be disposed of off site.

## **5.30 Ponds: DEAD STORAGE OR QUIESCENT PONDS**

Most ponds have some dead storage. In this manual, dead storage, or quiescent, ponds are ponds designed to primarily treat runoff in the storage area between events by inter-event settling and biological and chemical activity. They provide control of dissolved contaminants, such as phosphorus, as well as treatment of suspended particulates.

### ***PLANNING CONSIDERATIONS***

One of the main contaminants of concern for discharge to lakes is phosphorus. Suspended solids are highly correlated with other contaminants, but phosphorus usually has a sediment-related component and a dissolved component. Although most pond designs remove some phosphorus when they remove total suspended solids, the quiescent settling pond has been designed with additional phosphorus removal as its primary objective.

Dead storage or quiescent treatment ponds are often the largest pond designs. They have often been constructed with little consideration of temperature and aesthetics problems.

This type of pond often appears to be an easy fix because once treatment volume is selected, there is no need for additional calculation of outflow rate and bounce. However, failure to address these issues may lead to loss of vegetation or downstream flow-control problems. Dead storage ponds can be adapted to serve multiple purposes quite well, but this often requires additional design information.

### ***DESIGN RECOMMENDATIONS***

The size of this pond design can vary considerably, depending on the watershed size, soil types, amount of impervious surface and other factors.

#### **Pool Volume**

Quiescent ponds require a design ponding capacity, based on the characteristics of the local storm events and the variability of the period between storms. The most frequently used treatment volume is the watershed runoff from the one-year storm event (2.0- to 2.4-inch event in 24 hours), plus a volume for sediment control. Treatment is assumed to be accomplished by settling and biochemical activity during quiescent settling periods. Plug flow is desirable but less important to this design consideration.

For the one-year, 24-hour event, the permanent pool should be equal to or greater than the design runoff for fully developed watershed conditions. Use accepted hydrologic analysis methods to determine the volume of runoff. The volume used to size the pond is a total runoff volume, not an inflow outflow analysis. In most of Minnesota, this volume will provide an average hydraulic

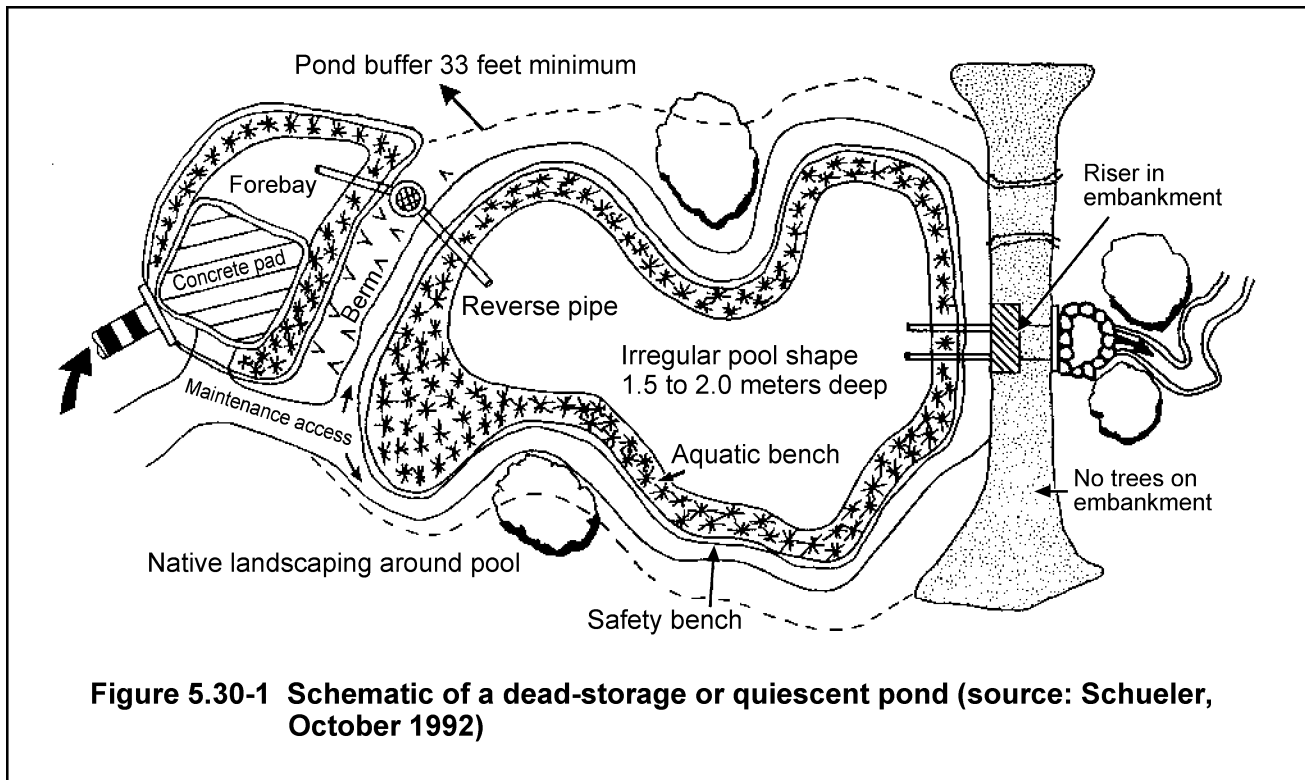

residence time in the pond of approximately 15 days for summer months. Sediment storage must be added to this volume to compute the total pond volume.

### Pond Depth

Once the treatment volume has been determined, the size of the pond is calculated by restricting the depth or surface area and then calculating other dimensions. The depth of the pond is usually restricted to 3 to 8 ft. Settling during events is not a design consideration, but resuspension is still a major concern. Flow dissipation and pond configuration should be carefully designed, especially for high-flow events, to prevent short-circuiting and resuspension.

The maximum depth should usually be 3 to 8 ft. If shallower depths are used, and little or no flow dissipation is used in the basin, fine sediments may be resuspended by flow or wind-generated currents. If depths of greater than 8 ft are used, the pond may be subject to temporary thermal stratification. This may result in releases of phosphorus from the anoxic or nearly anoxic bottom sediments. The phosphorus quantities may then be mixed back into the upper layer of the pond by flow or wind-generated currents. This mixing is referred to as “internal loading.”

### Pond Shape

“Plug flow” conditions are desirable in a wet pond to enhance water-quality benefits. In an ideal plug-flow situation, the pond volume would be totally displaced before new runoff is discharged

from the basin. This ideal condition will not occur, but the pond should be designed to encourage it as much as possible.

The most common shape of pond to promote plug flow is one that has a length-to-width ratio of 3:1 or more. This ratio may not be practical in some situations where site restrictions determine the pond shape. In some cases, energy dissipaters, inlet flow diffusers, baffles or flow directional berms can be used to prevent short-circuiting in ponds with small length-to-width ratios as described in “Minnesota Technical Release 8 (TR8),” (USDA, NRCS, 1988). Other ways to increase plug-flow characteristics are to construct variable bottom depths (Schueler, October 1992) or use two or more ponds in series that have a total volume equal to or more than the required treatment volumes and areas.

### **Outlet Controls**

The quiescent pond design does not specify the outfall structure to be utilized nor does it control the rate of discharge. The design engineers can utilize other applicable criteria, including particle size, average time between events, or flood routing and erosion control for the outlet design criteria.

## 5.40 Ponds: WETLAND TREATMENT

### *DESCRIPTION AND PURPOSE*

Wetland ponds are simply extended detention treatment ponds with vegetation-enhanced features. These ponds usually utilize active settling and other design concepts described above, but they require additional measures to protect vegetation (Schueler, 1992). They may also be designed to provide mitigation of impacts as described in the Minnesota Wetland Conservation Act.

Wetland treatment involves passing a carefully controlled volume of runoff through a natural or constructed wetland to remove or treat pollutants. Wetlands provide favorable conditions for removal of pollutants from urban runoff. Sedimentation and an intense pool of biological activity may help to remove nutrients during the growing season. Although wetlands are effective for removing pollutants, care must be taken in the design and operation of wetland treatment systems (see Figure 5.40-1).

### *TARGET POLLUTANTS*

Wetland treatment can be very effective for removing sediment and pollutants associated with it (such as trace metals, nutrients and hydrocarbons), oxygen-demanding substances and bacteria from urban runoff. Wetlands can also be effective during the growing season for removal of dissolved nutrients as well as those adsorbed to sediment.

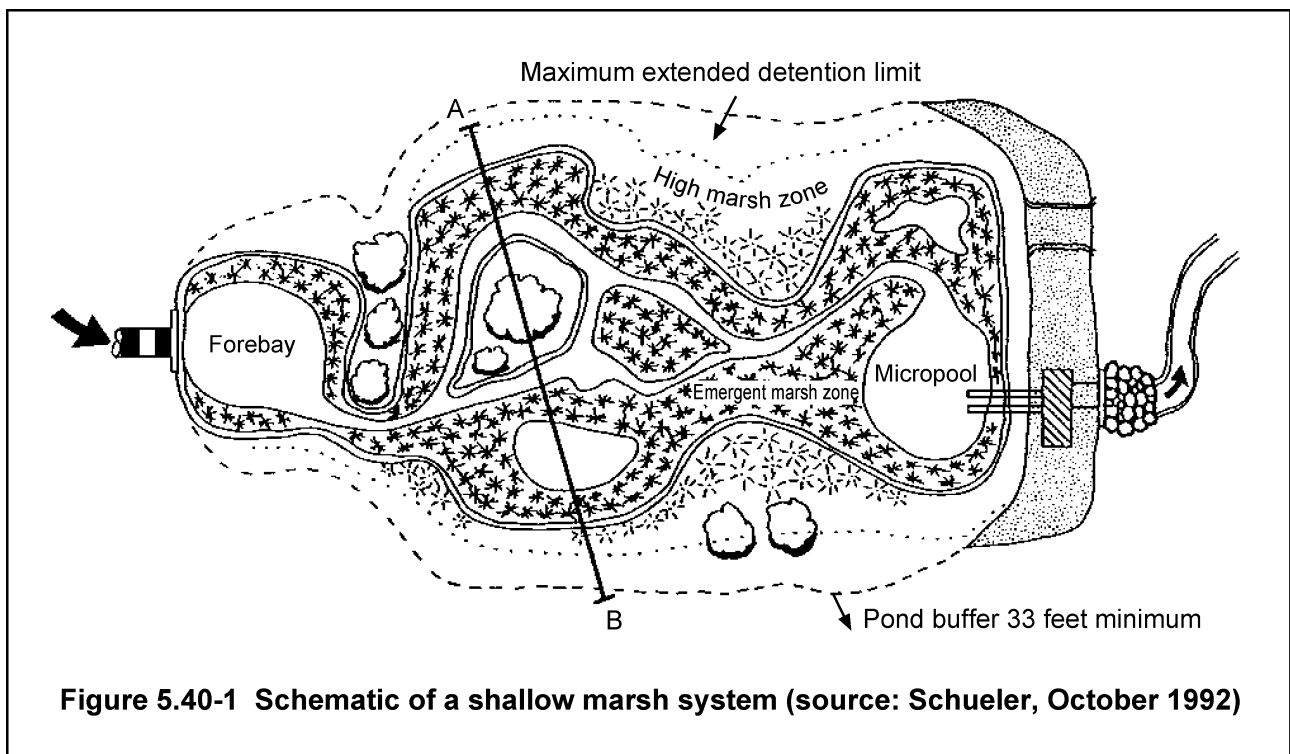

**Figure 5.40-1 Schematic of a shallow marsh system (source: Schueler, October 1992)**

## ***EFFECTIVENESS***

The effectiveness of wetland treatment systems for the removal of urban pollutants will depend upon the system's physical characteristics, such as wetland-size-to-watershed-size ratio, runoff residence time in the wetland, and water budget. In general, as the wetland-to-watershed area ratio increases, the average runoff residence time increases and the effectiveness of the wetland for pollutant removal also increases. Natural wetlands have often been altered by increased sediment and hydraulic loading. These wetlands often establish distinct channels and provide very little treatment. Outlet controls and flow-dispersion measures can reestablish treatment, but it must be done carefully so that the nature of the wetland is not destroyed.

Hickok *et al.* (1977) studied a wetland in Wayzata, Minnesota, with a drainage area of 72 acres and wetland area of 7.5 acres. The wetland in that study retained 78% of all phosphorus and 94% of all suspended solids entering it during the evaluation period. The effectiveness of wetlands for removing nutrients depends heavily upon the season. During the summer, when biological activity is maximized, nutrient uptake will be the greatest (Nichols, 1983; Brown, A.G.,1985). Phosphorus may release in fall die-off of vegetation.

## ***PLANNING CONSIDERATIONS***

Although wetlands are effective for removing pollutants, some drawbacks limit their use as a BMP. In response to the physical sedimentation process, pollutants associated with urban runoff, such as trace metals, will accumulate in the wetland sediment. Biological uptake of bioaccumulative materials by bottom-dwelling and -feeding organisms is a concern.

Any work within, or manipulation of, natural wetlands may be subject to state and/or federal regulations. Contact the MDNR or BWSR for the local unit of government delegated to regulate the Wetland Conservation Act in your area. Contact the Corps of Engineers Regulatory Branch at (651) 220-0375 for information on federal regulations and permits.

## ***DESIGN RECOMMENDATIONS***

Wetlands should have standard design features that take into consideration wetland size, bed and shoreline diversity, soils, wetland vegetation, wetland treatment and outlet designs.

### **Wetland Size**

The Metropolitan Council of Governments (Schueler, October 1992) has developed guidelines for constructing wetland stormwater basins. Those guidelines recommend a wetland surface area of 1 to 2% of the watershed area, depending on the nature of the watershed and the design of the facility. Pitt's (1996) pond-design recommendations of 0.6 to 3.0% of the watershed can also be used as a guide for wetland design.

It is often difficult to create a wetland with a drainage area less than 25 acres, unless the wetland is near the natural water table. For watersheds of less than 25 acres, there is simply not enough runoff to support hydric soil and vegetation.

## **Bed and Shoreline Diversity**

Aquatic benches for safety and erosion control should be about 3 to 10 ft wide with 10:1 slopes. When area is available, 10 ft is the recommended width.

Sediment forebay at the inlet just upstream to the wetland should be 4 to 8 ft deep, with access for cleaning.

Establish habitat for a variety of plant types. Bed and shoreline diversity establishes a more robust system of plants, able to adapt to variable hydrologic conditions. A healthy wetland may have dozens of wetland plant types.

A micropool should be established at the outlet to prevent resuspension of fine sediments and clogging.

Wetland outlets should be designed according to recommended design practices for ponds, with special measures to allow drawdown for wetland management.

## **Soils**

Soils at the proposed wetland site should have an infiltration rate low enough so that base flow or stormwater runoff can maintain a saturated soil or, if desired, a permanent pond. If readily available, natural wetland soils should be used for the bottom of the constructed wetland. Wetland soils usually contain hydrophytic plant propagules, which can be expected to grow in the new wetland. If these soils are not available, most other organic soils will allow the establishment of wetland vegetation as long as hydrologic conditions are adequate. An organic soil depth minimum of 4 inches is recommended.

## **Wetland Vegetation**

A constructed wetland can be vegetated by spreading wetland soils in the pool area. These soils will generally contain a large number of wetland plant propagules that can be expected to become established in the new wetland.

In some situations, wetland vegetation may need to be planted. This can be done by gathering planting stock from local wetlands or purchasing it from suppliers of these materials. It is best to use the expertise of professionals who can choose the appropriate plants for the specific wetland (See Dindorf, 1993; Schueler, 1992; and Henderson *et al.*, 1999).

## **Wetland Treatment**

The design criteria for wetlands are the same as those for active settling ponds. Wetland ponds can be designed to meet particle size removal efficiencies and treatment volume criteria. However, care must be taken to design the wetland so that the bounce in the pool is compatible with the wetland vegetation. The bounce must be considered in addition to any discharge requirements for particle size, flood control or downstream erosion control. The outlet in wetland treatment areas is not specified in this manual because discharge requirements should be somewhat flexible. However, standard extended-detention-basin design should be used for wetland outlets.

There is basis (Walker, 1990) for assuming that wetland treatment can provide more effective solids removal for an equal treatment area due to:

- laminar settling in zero-velocity zones created by plant stems,
- the anchoring of sediments by root structure, helping to prevent scour in shallow areas,
- increased biological activity removing dissolved nutrients, and
- increased biological floc formation.

However, these parameters must be considered on a site-specific basis.

Two major problems with wetland treatment are the release of nutrients in the fall and the need to maintain vegetation under a variety of flow conditions. The potential damage to wetland vegetation from changes in hydraulic and pollutant levels should be carefully analyzed. Pondscape design from Schueler (October 1992) can be used, but it should be modified for local conditions. When using wetlands as part of the treatment system, the wetland guidance *Storm Water and Wetlands: Planning and Evaluation Guidelines for Addressing Potential Impacts of Urban Storm Water and Snowmelt Runoff on Wetlands* (Minnesota, State of; June 1997) can also be consulted along with local experts and experienced professionals.

### **Outlet Design**

Extended detention design criteria (parts 5.05 and 5.20) are strongly recommended for the outlet structure design. An orifice or other outlet structure can be used to restrict the discharge to the required flow. Because of the abundance of vegetation in the wetland, a trash guard should be used to protect the orifice. A trash guard large enough so that velocities through it are less than 2 fps will reduce clogging problems. See part 5.06 on outlet design for more information on outlet devices.

### ***MAINTENANCE***

The key to using the wetland effectively is that the ponds must function so as not to destroy the wetland vegetation. Slight modification of operations and plantings may be necessary as operations proceed.

Sediment accumulation will be a major maintenance concern in shallow wetlands. Sediment accumulation could result in a loss of ponded area in the wetland or creation of channels that will cause short-circuiting of runoff through the wetland.

One way to avoid this is to provide one or more forebays in the wetland. The forebay pool should be located for easy access so that sediment can be removed regularly, before it threatens the wetland treatment efficiency. The pool can be deepened to extend the temporary storage volume, but when storage volume is reduced to the minimum that is acceptable, the forebay should be dewatered and the sediment removed.

Harvesting of wetland vegetation can also be considered to remove nutrients from the wetland system and to minimize nutrient release when vegetation dies in the autumn. This is not generally recommended, but in special cases it will remove the nutrients contained in the vegetation from the system. If vegetation is to be harvested, design features should be included that will allow the wetland to be dewatered (Schueler, October 1992).

## 5.50 Ponds: MODIFIED DRY PONDS

Traditional dry ponds have rarely been considered acceptable ponds from a water-quality perspective. The potential for scour and small detention times almost always eliminates these ponds from consideration as a water-quality BMP. However, designs that eliminate scour by controlling the flow through the pond can provide acceptable treatment. Enhanced swales and dry ponds that utilize extended-detention principles can serve to meet water quality goals; however, they must be carefully and properly designed, implemented and maintained.

To operate properly, these treatment systems need outlet controls with filters (Figure 5.50-1), weirs or other energy-dissipation and flow-spreading devices (Figure 5.50-2) constructed as part of the pond (Klein, December 1996). Because these types of basins do not have as much sediment storage volume as a typical wet detention basin, they need to be maintained more regularly. This usually increases maintenance cost of the project, and may significantly affect the initial costs as well. Proposed treatment systems of this nature should have long-term maintenance commitments and an established source of income to assure proper implementation.

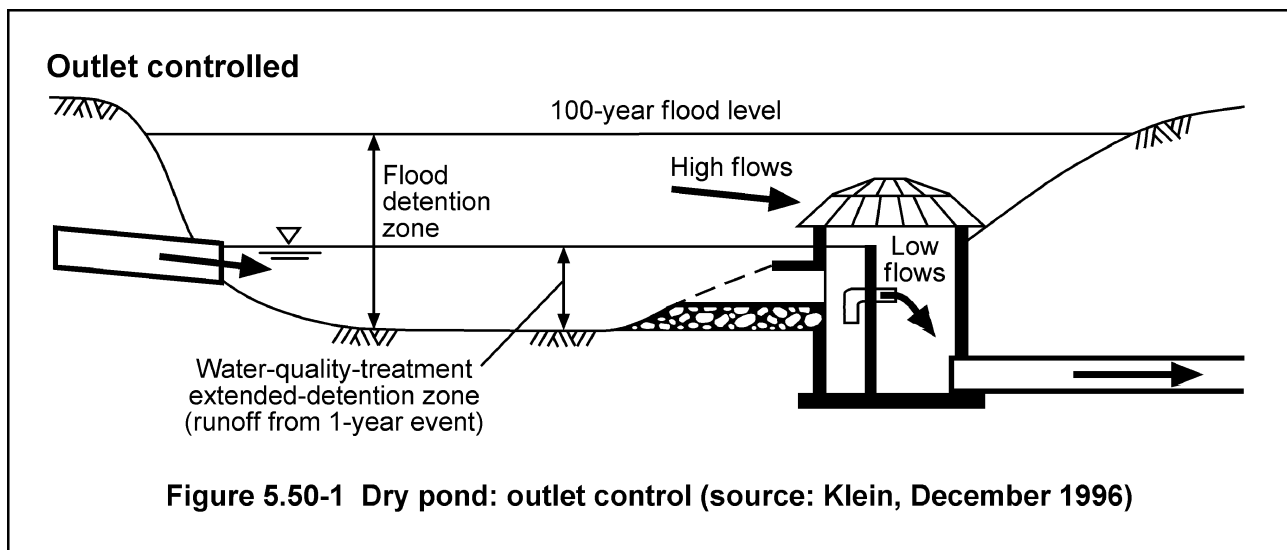

**Weir controlled**

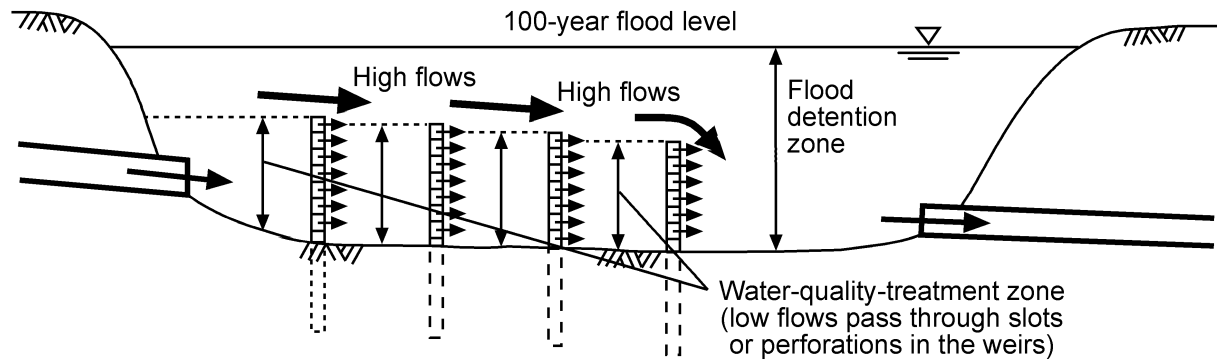

**Figure 5.50-2 Dry pond: weir control (source: Klein, December 1996)**

## **5.60 TEMPORARY PONDS**

## 5.61 Temporary Ponds: SEDIMENT BASINS

### *DESCRIPTION AND PURPOSE*

A temporary sediment basin is an impoundment that temporarily stores sediment-laden runoff and releases it at a reduced rate. During the time that the runoff is detained, sediment settles out and is trapped in the basin. This prevents the sediment from being transported off site.

### *EFFECTIVENESS*

Sediment basins are relatively effective for trapping medium- and coarse-grained sediment particles. However, fine silts and clays that are suspended in runoff are very difficult to trap. Overall trapping efficiencies of approximately 70% can be achieved with typical sediment particle size fractions and typical basin design. If higher trapping efficiencies are desired, larger pool volumes and slower discharge rates can be used. However, the value of increased sediment-basin size diminishes rapidly once sand and silt fractions of the sediment have been removed. Larger volumes reduce the chance of resuspension at higher-flow events, but this is less of a concern with temporary basins.

### *PLANNING CONSIDERATIONS*

Temporary sediment basins are normally used at the downstream end of disturbed areas of five to 250 acres. Temporary sediment basins are intended to be used only during the construction period of a development, usually less than two years. However, structures planned under this practice should be designed and constructed using the same standards as are used for permanent detention ponds, and may be restored after construction is completed to become permanent ponds.

If a permanent detention pond is desired, it should be built at the beginning of construction and also used and maintained for sediment control during construction. In this situation, the basin should be designed according to the applicable practice desired, with additional volume for the sediment and runoff expected during the construction period. Sediment should be removed from the pond at the end of the construction period to prepare it for permanent use.

Sediment basins should be located so that runoff from the largest possible erosion-prone area flows into them, but flows from the unaffected areas are diverted from them. Practices, such as diversions, can be used to control the area that is treated by a sediment basin. Temporary sediment basins should not be installed in streams. They should be located before the runoff from the site enters a stream.

### *DESIGN RECOMMENDATIONS*

- 1. Capacity.** Sediment basins are almost always associated with high-sediment-production areas, such as construction sites. For a sediment basin to be effective, it should have a permanent pool of water. However, special structures can be designed to control the flows in the sediment basin if the pool of water is not desired or maintainable. Figure 5.61-1 shows the

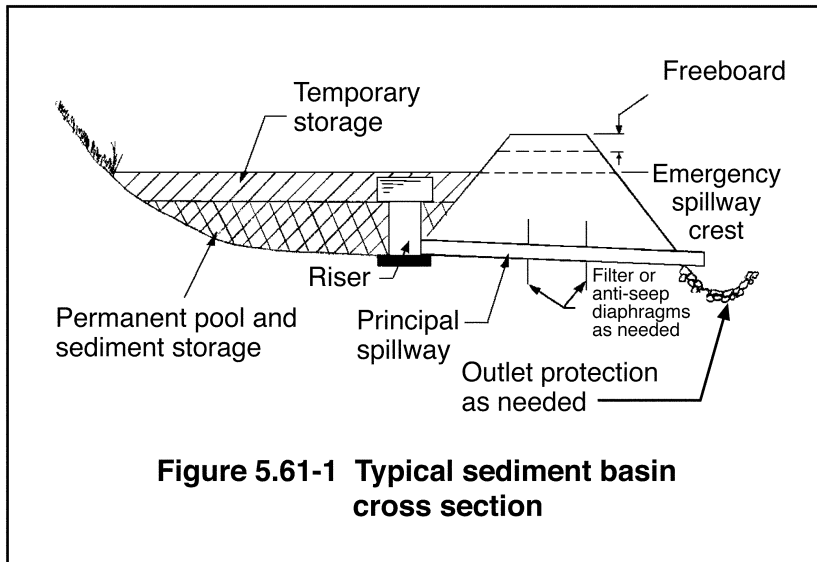

permanent and temporary volumes associated with typical sediment basins. The MPCA permit requires total storage volume below the principal spillway crest or first stage orifice to be at least 67 cubic yards per acre of drainage area (0.5 inch over the drainage area). When one-half of this volume is filled with sediment, the basin must be cleaned out to maintain its effectiveness.

2. **Principal spillway.** Principal spillways are often pipes that provide the main outlet for the temporary sediment basins. Principal spillways can be constructed of a variety of materials, such as corrugated metal, high-density polyethylene (HDPE), polyvinyl chloride (PVC) or concrete. For temporary sediment basins, corrugated metal is often used because it is relatively easy to remove and reuse once the basin has been abandoned. HDPE and PVC also are easily removed. The pipe must be watertight, but special coatings for corrosion protection are not typically needed because this is a temporary practice.

Principal spillways should be designed with a maximum outflow ( $Q_{out}$ ) of 5.66 cfs or less per acre of pond surface area, up to the water quality volume. Smaller outflows will result in higher efficiencies, but larger temporary storage volumes. The required storage volume can be determined from the design procedures described in part 5.05. The storm that should be routed for the principal spillway depends upon the downstream environmental and safety impacts if the system exceeds design capacity.

When determining the capacity of a principal spillway, first check the capacity of the pipe. Second, check weir flow and orifice flow at the riser entrance. If weir flow or orifice flow controls the peak flow from the structure, a larger riser may be required. In some cases, orifice flow at the entrance to the principal spillway pipe should be checked also.

In some cases, the required discharge from a temporary sediment basin will be small enough that a slotted riser and PVC pipe may be used as a principal spillway. Figure 5.61-2 shows a slotted riser and PVC pipe that is used as an outlet for a sediment basin. Slotted risers can either be constructed from a solid pipe or they may be purchased as prefabricated components. Riser slots must be covered with filter fabric and/or gravel filter to prevent undesirable sediment washout.

At the inlet to the principal spillway, a skimmer-type debris trap should be used. If considerable amounts of floating debris are expected, a trash rack and anti-vortex baffle can be used. Figure 5.61-3 shows a typical installation for corrugated metal risers. These are recommended only for temporary facilities.

## ***MAINTENANCE***

Sediment basins require occasional maintenance to remain effective as sediment traps. When sediment reaches the maximum level assumed in the design (usually one-third to one-half the basin volume), it must be removed. Excavated sediment must be placed in a location where it will not easily be eroded again. In addition to sediment cleanout, sediment basins should be inspected after storms to determine whether the embankment or spillways sustained any damage that requires repair.

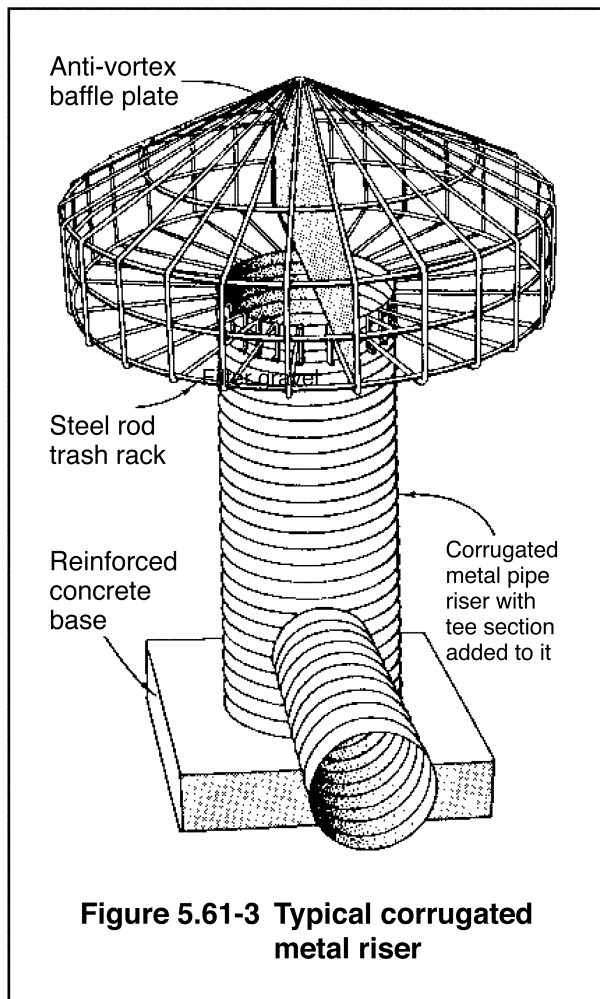

## **5.62 Temporary Ponds: SEDIMENT TRAPS**

### ***DESCRIPTION AND PURPOSE***

A temporary sediment trap is a small, temporary ponding area formed by constructing an earthen embankment with a gravel outlet swale instead of using a pipe for the primary outlet. Temporary sediment traps are intended to detain sediment-laden runoff from small disturbed areas long enough to allow the majority of the larger sediment particles to settle out.

### ***EFFECTIVENESS***

Temporary sediment traps provide good control of coarse sediment and are moderately effective for trapping medium-sized sediment particles. However, they have a relatively low trapping efficiency for fine silt and clay particles suspended in runoff. If a higher trapping efficiency is desired, a temporary sediment basin with a larger storage volume and longer detention time should be used.

### ***PLANNING CONSIDERATIONS***

For maximum effectiveness, sediment traps should be located as close as possible to the disturbed area. Multiple sediment traps are often needed to treat runoff from ever-changing construction sites. Temporary diversions can be used to direct sediment-laden runoff to the sediment trap. Every effort should be made to exclude runoff from undisturbed areas. Sediment traps and other sediment-control measures should be installed before work is begun in the contributing drainage area.

### ***DESIGN RECOMMENDATIONS***

1. A temporary sediment trap should typically be used in a location with a drainage area of five acres or less and where it will be used for two years or less. The volume of the trap should be at least 67 cubic yards per acre of watershed.
2. The gravel outlet swale must be capable of handling the runoff from a 10-year frequency, 24-hour-duration storm without failure or significant downstream erosion.
3. If a pipe outlet is desired, see Stormwater Detention Pond Design Details and Examples (section 5.70) and Temporary Ponds: Sediment Basin (part 5.61) for design requirements.
4. The gravel outlet should be located in the low point of the embankment. The minimum length in feet of a gravel outlet should be four times the number of acres in the drainage area. The peak velocity in the basin should be 4 fps for the 10-year storm event. The crest of the gravel outlet should be level and should be 1 ft below the top of the embankment. See Figure 6.41-1.
5. The gravel used for the outlet should be 1- to 2-inch size, such as MnDOT CA-1 or CA-2 coarse aggregate. A filter fabric can be installed inside the gravel filter to improve the sediment-trapping efficiency of the structure. However, this increases the probability that the outlet will become clogged with sediment.

## ***MAINTENANCE***

As previously mentioned, the sediment should be removed when it fills one-third to one-half of the capacity of the sediment trap. If the outlet becomes clogged with sediment, it should be cleaned to restore its flow capacity.

The structure should be inspected after significant runoff events to check for damage or operational problems. Once the contributing drainage area has been stabilized, the structure can be removed or, if possible, modified to become part of the permanent control features.

### **5.63 Temporary Ponds: TEMPORARY SEDIMENT-CONTROL PONDS**

Current regulations in Minnesota require “temporary sediment-control ponds,” which is a type of temporary pond required in the MPCA Construction Storm Water Permit. These temporary ponds are required where 10 or more contiguous acres of exposed soil contribute to a discernible point of discharge, prior to the runoff leaving the construction site or entering waters of the state.

The permit states that “the basin shall provide 1,800 cubic ft per acre drained of hydraulic storage below the outlet pipe.” This is equivalent to the 67 cubic yards recommended by the NRCS for sediment basins (USDA, NRCS, June 1988). The permit requires that the basin outlets be designed to prevent short-circuiting and the discharge of floating debris. The outlet should consist of a perforated riser pipe wrapped with filter fabric and covered with crushed gravel. The perforated riser pipe should be designed to allow complete basin drawdown. Although these basins are for temporary use, usually considered to be two years, the time period during which they can be utilized is not specified.

**5.70 STORMWATER DETENTION POND DESIGN DETAILS AND  
EXAMPLES**

## 5.71 Stormwater Detention Pond Design Details and Examples: SPECIFICATIONS

### 1. Embankments

The minimum recommended top width of embankments are given in Table 5.71-1.

**Table 5.71-1 Minimum recommended top widths of embankments**

Total Embankment Height (feet)	Top Width (feet)
< 10	6
11-14	8
15-19	10
20-25	12

The side slopes of the embankments should be flatter than 2:1 and the combined upstream and downstream slopes should be 5:1 or more. For example, 3:1 upstream and 2:1 downstream would be satisfactory.

A core trench is needed for all embankments more than 7 ft high (see Figure 5.71-1). If the core trench is not required, the base should be stripped and

scarified before placing fill. If a core trench is needed, it must be at least 4 ft deep and should have side slopes of at least 1:1.

To prevent failure, the embankment for a temporary sediment basin needs to be constructed to the same standards as those for small dams. Materials used in the embankment must consist of soils that have adequate strength, low permeability and piping resistance to be used in a water-impounding structure. Fill materials containing sod, roots, trees or other debris should not be used.

During construction, the moisture content of the fill material should be such that a ball that does not readily crumble can be formed in the hand. Very wet or dry soil will not compact properly. The embankment should be relatively homogeneous and free of dry or uncompacted layers. Extra care is

needed when compacting fill around the principal spillway. This fill should be tamped with hand-directed power tampers. The embankment should be compacted by routing the earth-moving equipment over it until the entire surface of each lift is covered by at least two passes of equipment with wheels or three passes of equipment with tracks. Each lift should not exceed 9 inches in thickness.

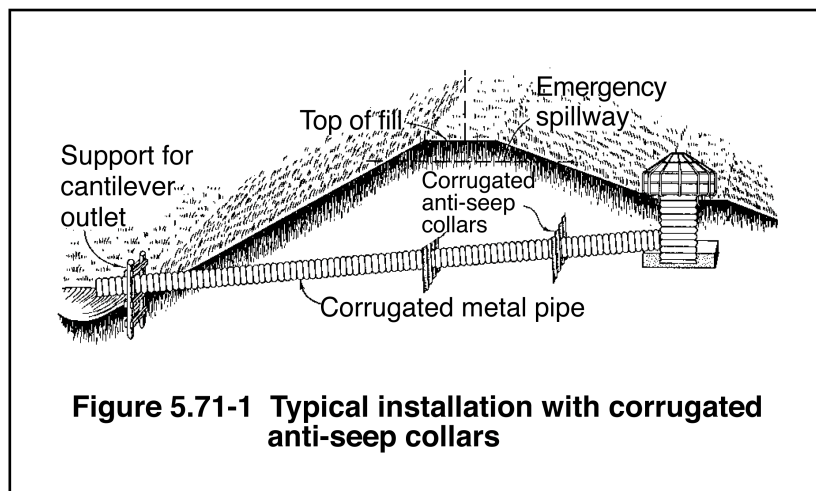

## 2. Filter Diaphragms or Anti-seep Diaphragms

Filter diaphragms have become the preferred method, but either filter diaphragms or anti-seep diaphragms can be used if properly installed.

Anti-seep diaphragms or filter diaphragms are needed on principal spillway conduits to control seepage and piping when one of the following conditions exists:

- The height of the dam exceeds 15 ft.
- The conduit is made of smooth pipe larger than 8 inches in diameter.
- The conduit is corrugated pipe larger than 12 inches in diameter.

When anti-seep diaphragms are used, they should be designed to increase the seepage length along the pipe by 15%. More than one diaphragm may be needed to achieve this. All connections for anti-seep diaphragms must be watertight. When installing a conduit with anti-seep diaphragms, it is very important to properly compact the earth fill adjacent to the diaphragms and adjacent to the pipe. Figure 5.71-1 shows a typical installation with anti-seep diaphragms.

Filter diaphragms are another acceptable means of controlling seepage along principal spillways. Figure 5.71-2 shows a typical filter diaphragm installation.

Filter diaphragms are constructed of granular material of proper gradation to allow seepage to pass through them while preventing migration of embankment soil particles. A geotextile may be used to prevent soil migration. A granular bedding for the pipe may be used downstream of the diaphragm as an outlet.

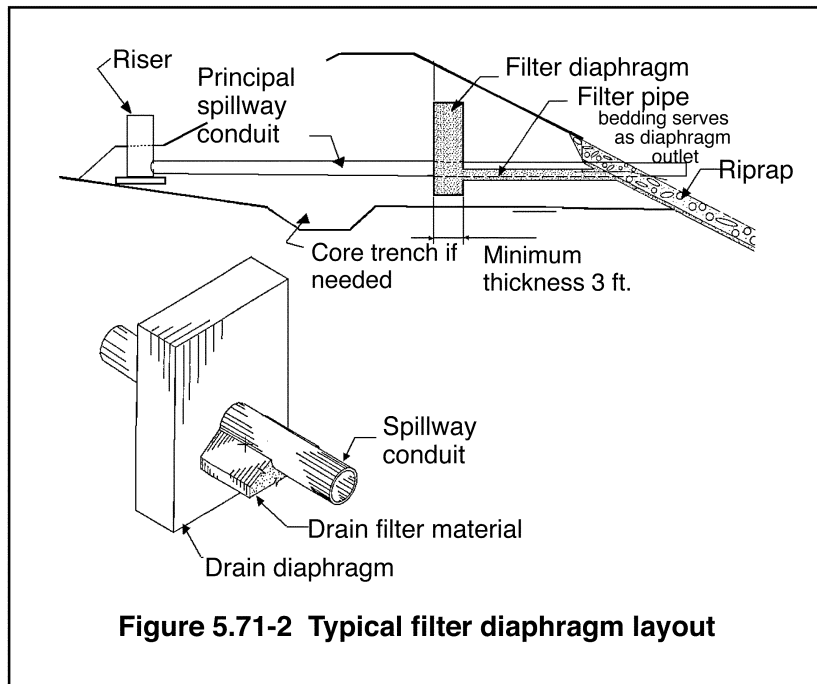

A filter diaphragm should extend horizontally and vertically three times the outside diameter of the conduit. However, the diaphragm does not need to extend higher in elevation than the maximum pool level. The filter diaphragm should be at least 3 ft thick.

For more information on filter diaphragm design procedures, consult SCS Technical Release 60, *Earth Dams and Reservoirs* (SCS, USDA, October, 1985), and SCS Soil Mechanics Note 1, *Guide for Determining the Gradation of Sand and Gravel Filters* (SCS, USDA, 1985a).

**Table 5.71-2 Recommended minimum design frequency**

Drainage Area (acres)	Minimum Pipe Diameter	Effective Fill Height (ft)	Minimum Design Frequency (years)		
			Maximum Storage (ac-ft)	Principal Spillway	Emergency Spillway*
0-20	5	0-20	50	--**	10
0-20	5	20-35	50	2	25
20-80	6	0-20	50	5	25
20-80	6	20-35	50	5	50
80-250	10	0-20	50	10	25
80-250	10	20-35	50	10	50
All others	15	0-35	--	25	50

\* Freeboard is the difference in elevation between the water surface in the vegetative spillway during the passage of the emergency-spillway-design storm and the top of settled fill. The minimum freeboard should be 1 ft.

\*\* A principal is required on all embankment ponds except where the drainage area is under 20 acres *and* there is no spring flow or base flow *and* the emergency spillway is in good condition. If there is no principal spillway, a trickle tube or underground outlet is required.

### 3. Emergency Spillways

An emergency spillway is needed for all temporary sediment basins. As a minimum, the emergency spillway capacity should meet the requirements in Table 5.71-2. Emergency spillways should have a minimum bottom width of 10 ft and a level section of 30 ft or more. Emergency spillways should be excavated in undisturbed soil rather than fill material. Use Table 5.71-3 to determine the appropriate spillway width and depth of flow.

After determining the depth of flow, the freeboard from Table 5.71-2 must be added to determine the elevation of the top of dam. Figure 5.71-3 shows a typical emergency spillway layout.

Figure 5.71-4 shows some emergency spillway design features.

### 4. Basin Shape

The shape of the sediment basin should be laid out so that the length-to-width ratio is at about 3:1, but it can be any shape, including circular, if the flow is properly dispersed across the entire area. To disperse the flow, gabion or plunge pool inlets or other energy-diffusing devices may be used, especially if the inlet has a high velocity (see Figure 5.71-5). If site constraints prevent the construction of a basin that meets this criterion, baffles such as those shown in Figure 5.71-6 can be used.

### 5. Inlet Conditions

Measures should be taken to minimize turbulence that will disturb the settling conditions of the sediment basin. If a high velocity flow is allowed to enter directly into the basin, it can resuspend sediments and prevent settling within the basin.

**Table 5.71-3 Emergency spillway widths (feet)**

Cfs	Depth of Flow (feet)	
	1.0	1.5
	10	not applicable
20	13	not applicable
25	17	not applicable
30	20	not applicable
35	24	9
40	27	10
45	30	11
50	33	12
60	40	15
70	47	17
80	54	19
90	60	22
100	67	24
125	84	30
150	100	36
175	117	42
200	134	48
250	167	60
300	200	72
The exit slopes for emergency spillways with flow depths of 1.0 and 1.5 cubic ft per second must fall within the following ranges for this table to be used.		
Flow Depth	Exit Slope (percent)	
	Minimum	Maximum
1.0	5	15
1.5	4	8

Pipe inlets that create a jet of water, or turbulence, in the sediment basin should be avoided. Measures that can be used to minimize turbulence are discussed in other chapters of this manual. They include baffles (see Figures 5.71-5 and 5.71-6), transition sections in channels, outlet dissipation devices and riprap.

## 6. Drawdown Devices

The pool below the principal spillway crest can be dewatered if this is done in a manner that preserves the trapping efficiency of the sediment basin. There are two methods of dewatering that can be used.

The first method is a slow discharge at the sediment pool level that will lower the pool level to that elevation over a period of several days. This can be done by using an orifice in the riser, a siphon or a separate dewatering device. A maximum rate of discharge of approximately 0.12 cfs per acre ft of pool volume between the sediment storage level and principal spillway crest is recommended. Figure 5.71-7 shows several methods of dewatering. Slotted riser specifications are shown in Figure 5.71-8. These outlets should be wrapped in filter fabric or gravel filters as shown in Figure 5.71-7. They are for temporary ponds only.

Another method of dewatering is to install a perforated drain in the bottom of the sediment basin pool (see Figure 5.71-9). This configuration has the advantage of also dewatering the sediment, which makes it easier to excavate. This type of outlet may be subject to clogging by fine sediments, especially at construction sites.

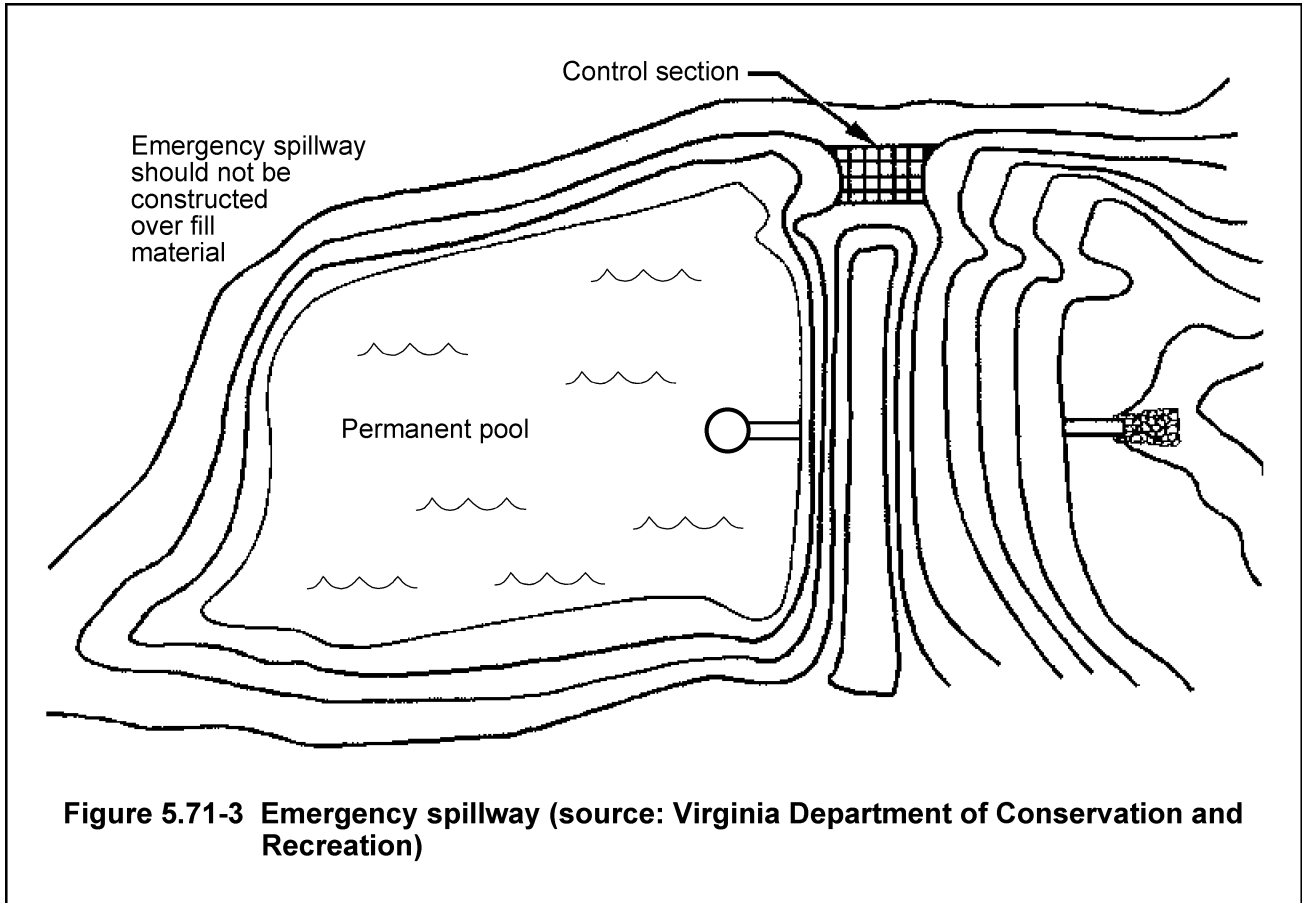

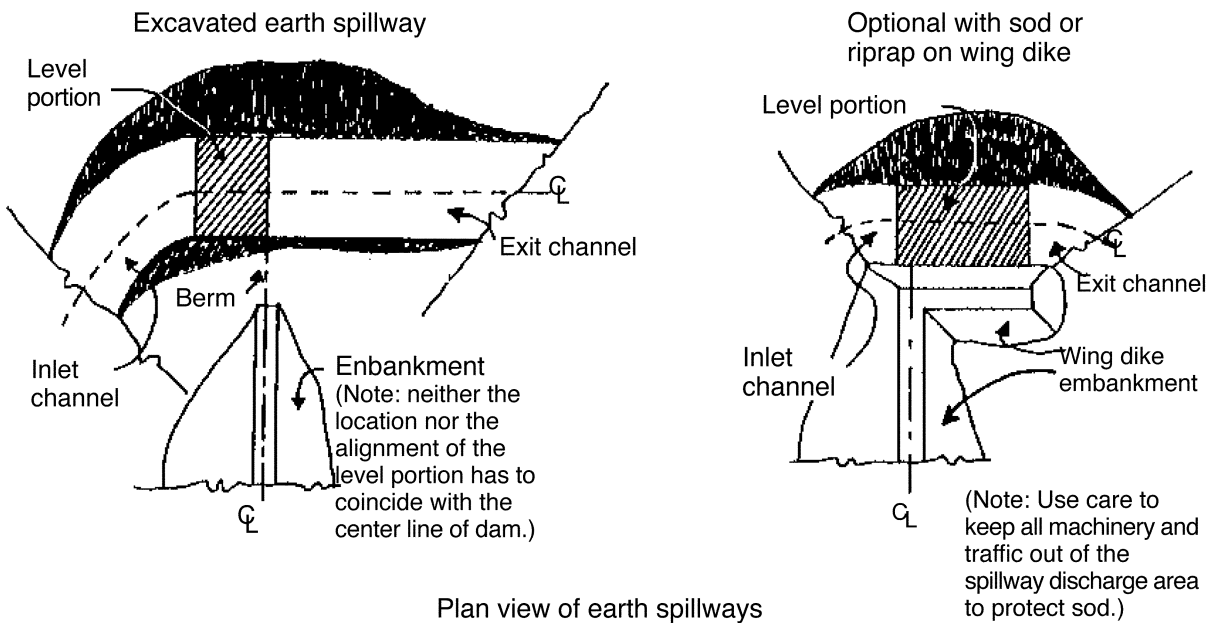

Plan view of earth spillways

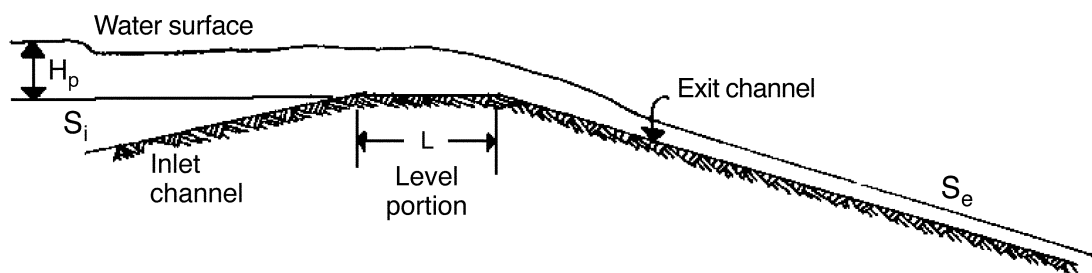

Profile along centerline

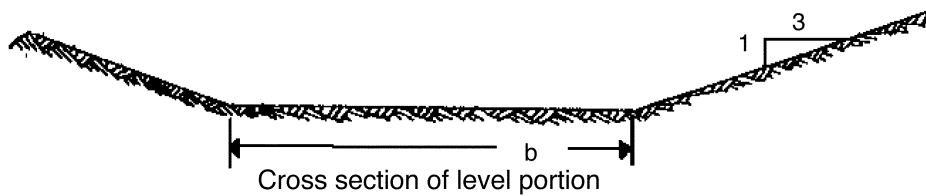

- |   |                                |
|---|--------------------------------|
| $H_p$ = Depth of water in reservoir above crest | $S_e$ = Slope for exit channel |
| $L$ = Length of level portion (minimum)         | $S_i$ = Slope of inlet channel |
| $b$ = Bottom width of spillway                  | $C$ = Center line              |

**Figure 5.71-4 Typical emergency spillway layout**

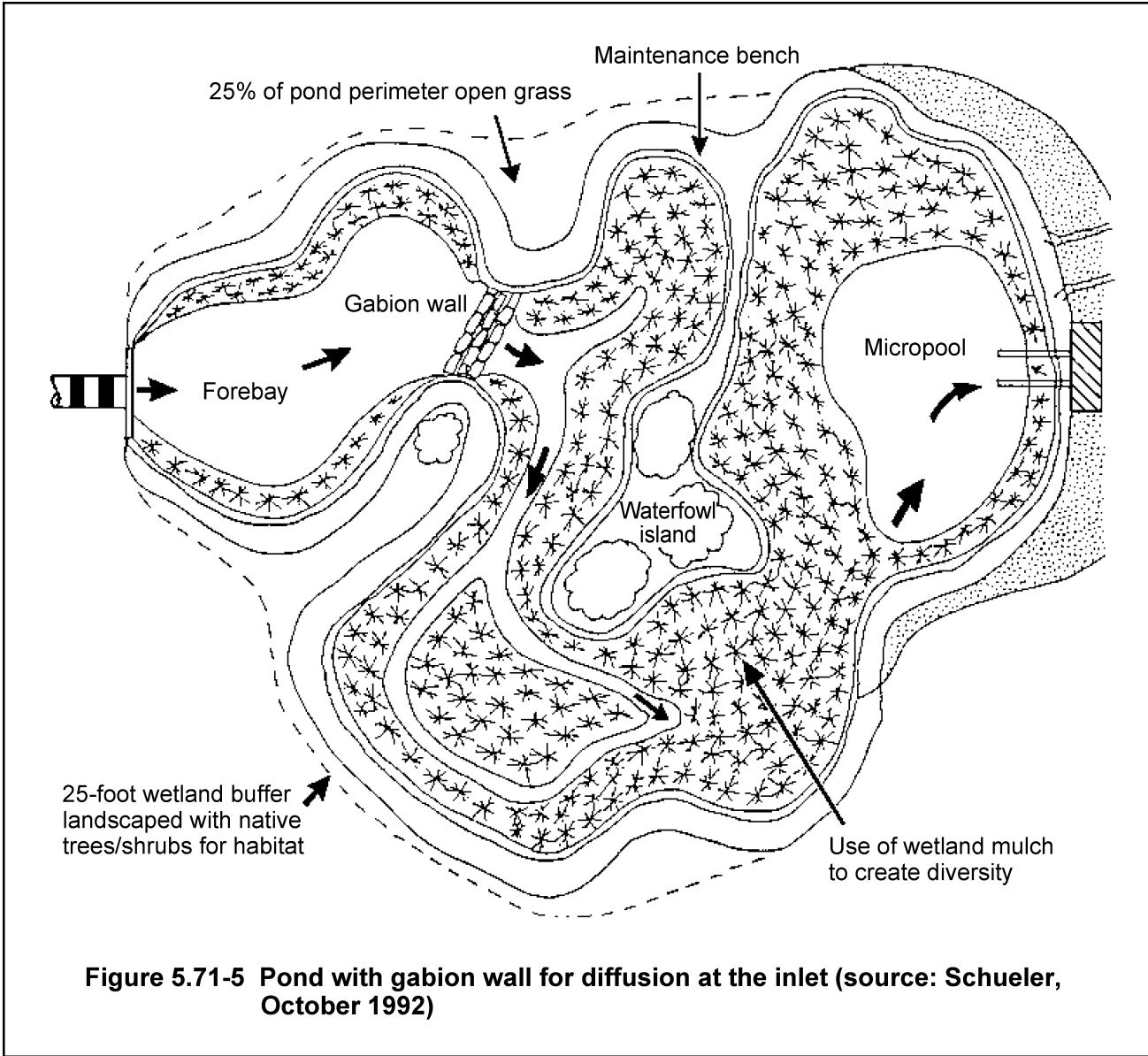

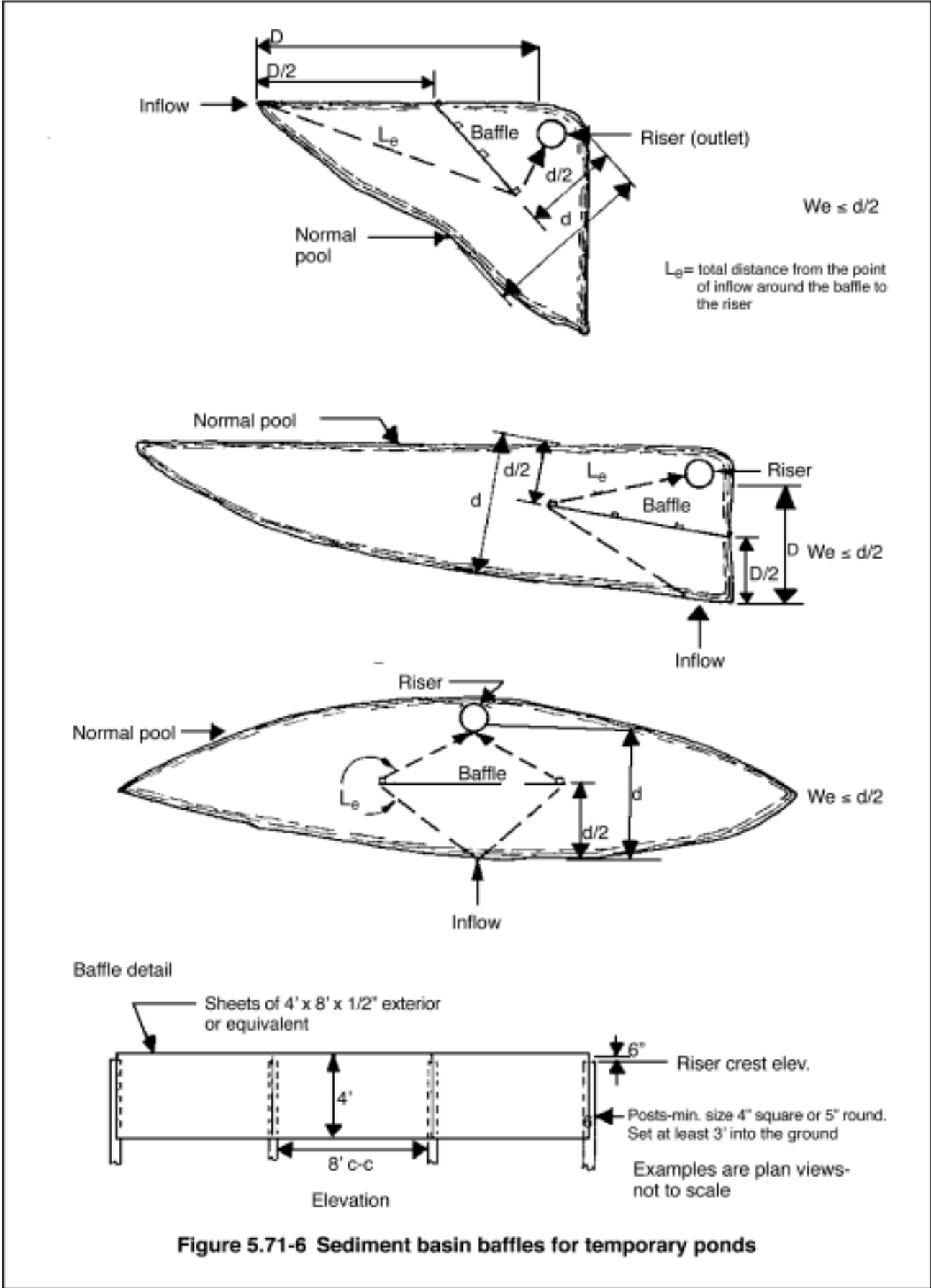
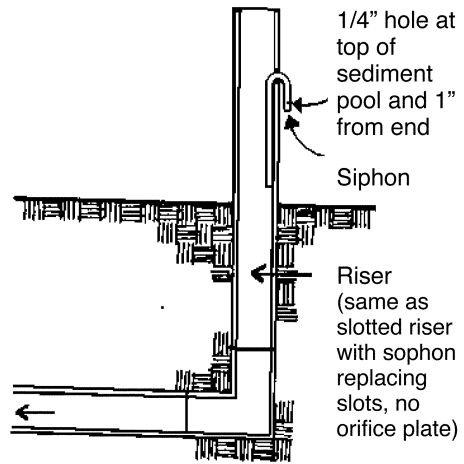
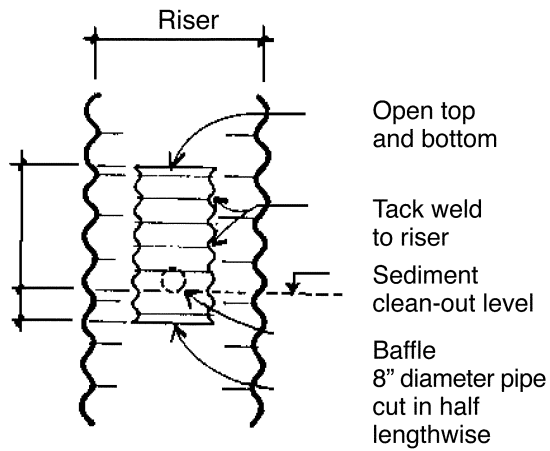
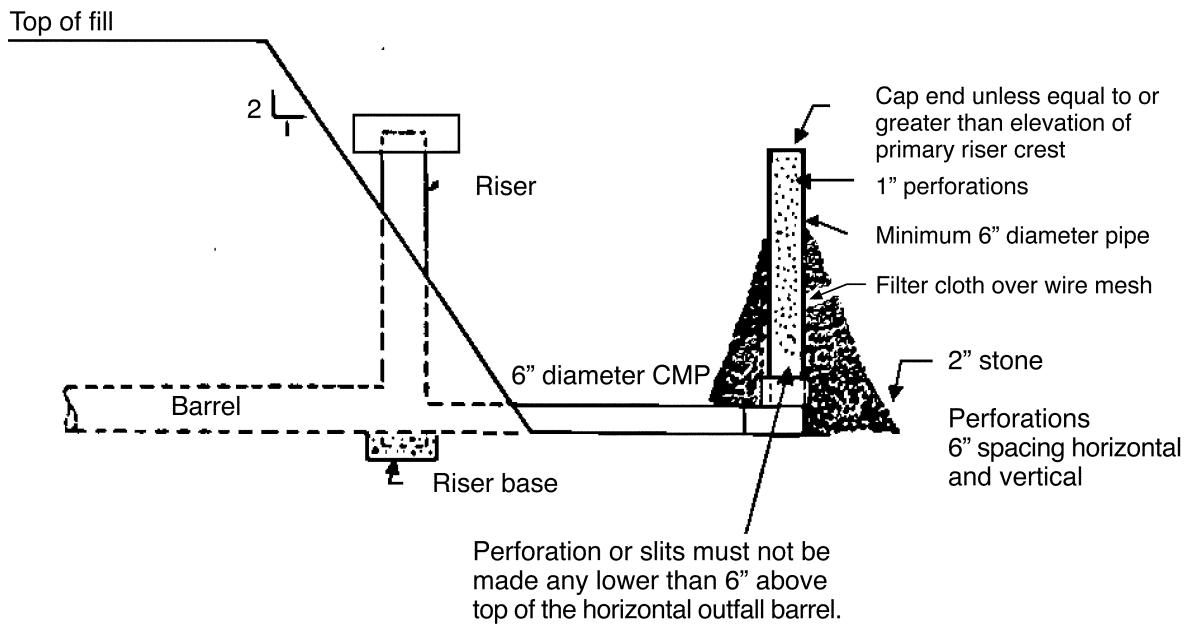

Figure 5.71-6 Sediment basin baffles for temporary ponds



Baffle inlet on principal spillway  
(Baffle protects orifice from clogging.  
Rate of discharge by orifice very small under low head.)

Method B: Principal spillway pipe with siphon



Optional sediment basin dewatering device with 6" slotted riser

**Figure 5.71-7 Sediment basin dewatering devices**

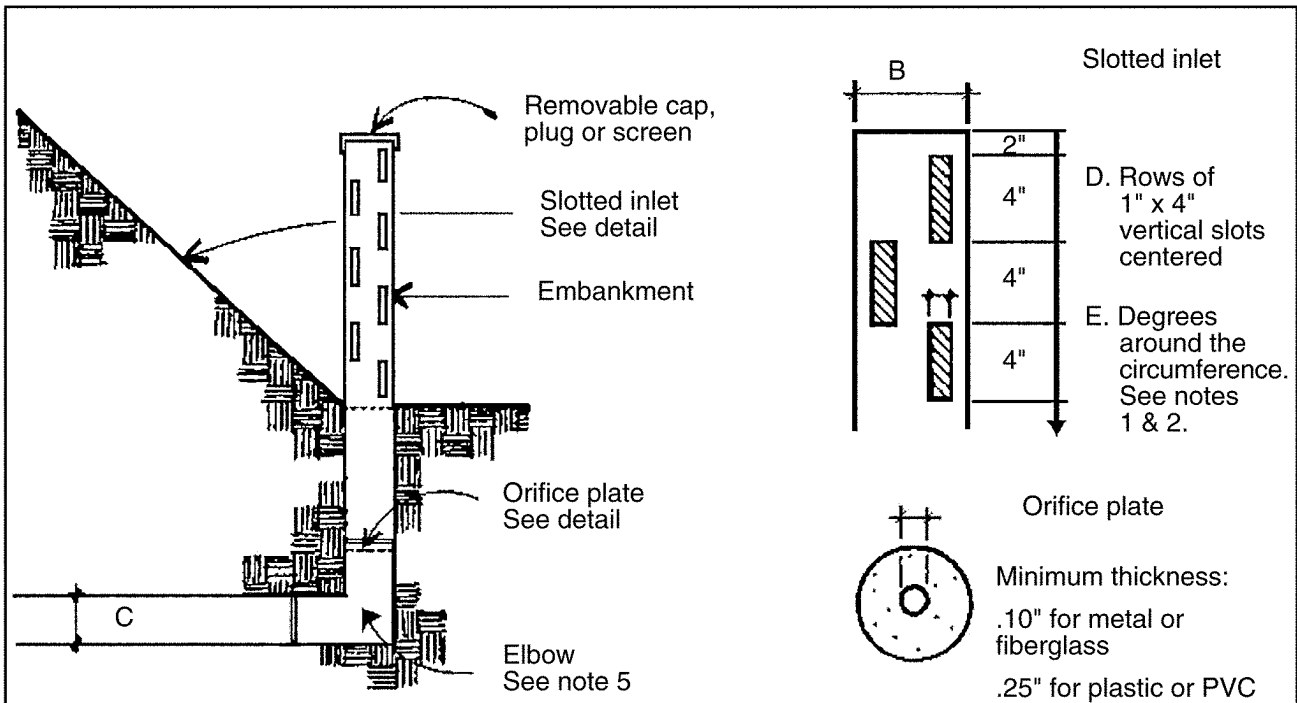

Principal spillway pipe with slotted riser

Standard Dimensions Table								
A in.	B in.	C in. Min.	D rows	E degr.	Slot area Ft <sup>2</sup> /ft	Minimum wall thickness		
						corrugated metal base	smooth steel in.	PVC in.
1.50-3.50	6	4	4	90	.167	16	.10	.15
3.75-5.50	8	6	6	60	.250	16	.10	.20
5.75-6.00	10	8	8	45	.383	16	.13	.25

Notes and Comments

1. Slotted inlets shall be fabricated from corrugated metal, smooth steel or PVC plastic pipe. Materials shall have at least the minimum wall thickness given in the standard dimensions table.
2. Slots shall be cut cleanly and deburred. Ends of slots may be round or square.
3. Orifice plate, cap and all fittings shall be snug and securely fastened. Orifice plate shall be cleanly cut and free of burrs with care taken not to round the edges. It should be a minimum of 2.0 feet below grade for proper functioning.
4. The portion of the inlet below grade may be perforated with a gravel filter for additional dewatering of basin.
5. Fabricated or standard elbow, fabricated or standard tee with main tile line or plug in upstream and, or standard tee with one end embedded in concrete.
6. The height if inlet is above the sediment pool level shall be such that the velocity of flow through the slots is less than 2.0 feet per second.
7. Head on the orifice, if placed as suggested, may be figured by adding 0.7 times the maximum depth of impounded water plus the depth of the orifice below grade. Has a relatively constant rate of change.

Figure 5.71-8 Slotted riser standard dimensions

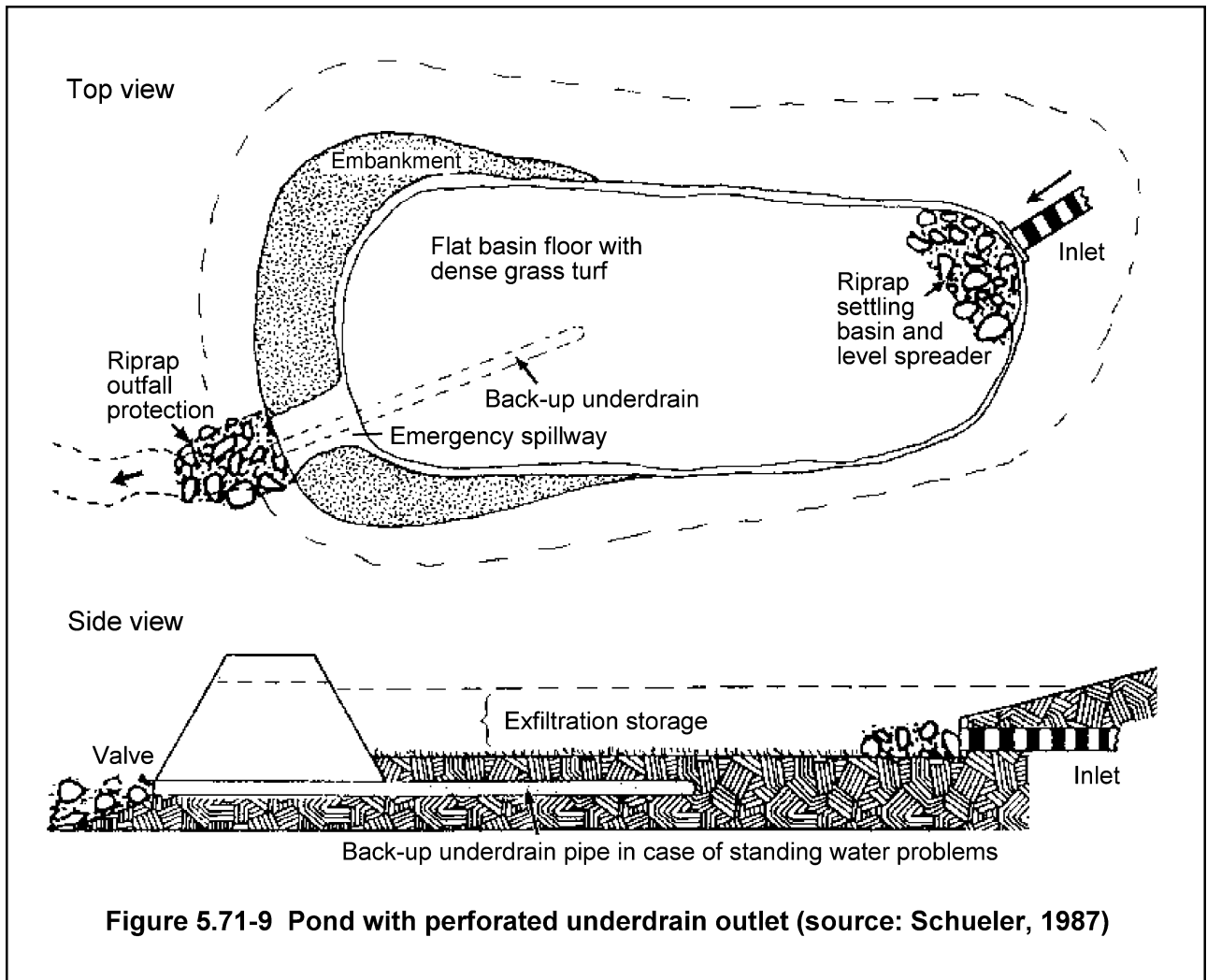

## 5.72 Stormwater Detention Pond Design Details and Examples: EXAMPLE OF A SIMPLE DESIGN

**Example site:** 100-acre site, predevelopment CN = 70. Postdevelopment: Residential area with 1/3-acre lots. B soils (much of it disturbed). From TR55 Residential 1/3-acre lots = 30% impervious, CN options for pervious soils is 57-86, chose CN=80 for sodded but disturbed B soils.

**Pond size:** From Pitt, for residential 1/3-acre lots, 0.8% of 100 acres = 0.8 acres of permanent pond.

Volume of permanent pond (must meet sediment storage-, inlet- and outlet-design criteria). The minimum is the MPCA permit, which requires 250 ft<sup>3</sup> per impervious acre of area drained. 250 ft<sup>3</sup> x 30 acres / 43,560 ft per acre = **0.17 AF**. Another widely recommended volume is 0.5 inch times the impervious surface. 0.5 x 30 acres x 1/12 inch per foot = **1.25 AF**. The Metropolitan Council (Oberts, 1986) recommended 0.5 inch of runoff from entire watershed.; 0.5 inch x 100 acres / 12 inches per foot = **4.2 AF**. Wisconsin has recommended the water quality volume be used; in Minnesota, that would be the runoff from the 1.25-inch event or 0.29 inch x 100 acres / 12 inches per foot = **2.41 AF**.

Alternatively, we could use a quiescent storage design with runoff from 2 times the water quality event (1.25-inch event) which is the 2.5-inch event. Using NRCS composite CN methods, this event produces 0.89 inch of runoff or: 0.89 inch x 100 acres / 12 inches/foot = **7.41 AF** storage.

The specific volume is not as important as meeting the goals for treatment, and the design criteria for inlet, outlet, diffusion of flow, velocity dissipation, etc. For this example, use 2.41 AF storage below the outlet and extended detention for treatment.

### Water Quality Volume

The water quality volume = 1.25-inch event; From TR55, runoff volume = 0.29 inch x 100 acres/12 in/ft = 2.41 acre ft.

Regulatory (MPCA Permit) water quality vol. = 0.5 inch from impervious surface; 0.5 x 0.3 x 100 acres x 1 foot / 12 inches = 1.25 acre ft. **Use 2.41 acre ft for water quality volume.**

### Water Quality Volume – Elevation

(Needs to be an actual, site-adjusted stage-area-discharge curve.)

Assume 0.8-acre permanent pond, 3.0 ft depth average. Assume a 1.0-acre pond at depth of water quality volume.

Estimate of water quality volume depth, Average area = (0.8+1.0 ) divided by 2, 1.8 acres, /2= 0.9 acre average area. Average depth = volume /average area = 2.41 acre ft / .9 acre = 2.7 ft deep.

(Note: This is a modification of the normal process where the site areas and volumes are usually known or can be calculated from the site features.)

**Water Quality Volume – Discharge**

(Needs to be site-adjusted stage discharge curve.)

Restrict discharges up to 2.7 ft of depth by limiting outflow to 5.66 cfs per acre of surface area in pond, maximum pond surface area is 1.0 acre; therefore, maximum outflow = 5.66 cfs at 2.7 ft deep.

**Flood Discharge**

(Needs to be site-adjusted stage-discharge curve.)

Design outlet to discharge at a rate of 1/2 of the predevelopment two-year event, and equal to the predevelopment 10- and 100-year storms, routing the storms through the pond.

**Velocity in Pond**

(Needs to be site-adjusted stage-discharge curve.)

Demonstrate that critical velocities in the pond do not exceed guidance criteria. Velocity = flow out divided by critical cross sectional area. Limit to 2 fps at one-year storm, 3 fps at two-year storm, 5 fps at 10- and 100-year storm events using site-specific determinations.

## **5.73 Stormwater Detention Pond Design Details and Examples: EXAMPLE OF A COMPLEX DESIGN**

The following example illustrates some key points that should be addressed in the design process. It is not meant to be all-inclusive. Professional knowledge of the models and methods of design are indispensable to this process.

### **Given Situation for This Example**

A property owner proposes to develop 100 acres (2,087 ft x 2,087 ft) of open, grassed area. The present area is fairly well drained with a single point of discharge. Natural slope of the land is fairly level, about 1%, but slopes gradually increase near the outlet. In the northeastern corner, slopes average about 10:1, horizontal to vertical. The soil is group B (USDA, NRCS, October 1986). Predevelopment condition is short grass in good condition.

In the developed condition, about 20 acres (1,500 ft x 580 ft) would be commercial development. The 20-acre commercial site will have disturbed B soils, with impervious surfaces about 85%. Commercial impervious surfaces will all be connected directly to the pond.

The remainder would be 80 acres of residential development with 1/3-acre lots. About 30% impervious surfaces. Residential impervious surfaces will all be directly connected to drainage ways, but not to storm sewers.

Precipitation for 24-hour events (USWB, TP 40) is approximately:  
two-year event = 2.75 inches;  
10-year event = 4.2 inches;  
100-year event = 6.0 inches.

**Given the above situations, design a pond that meets state and local goals.**

### ***Step 1. Plan and site the stormwater-treatment pond.***

The pond should be planned and sited in accordance with planning and design strategies recommended in this manual. Important considerations include the established goals for the watershed and the site-specific feasibility of on-site or regional ponds.

## Site plan

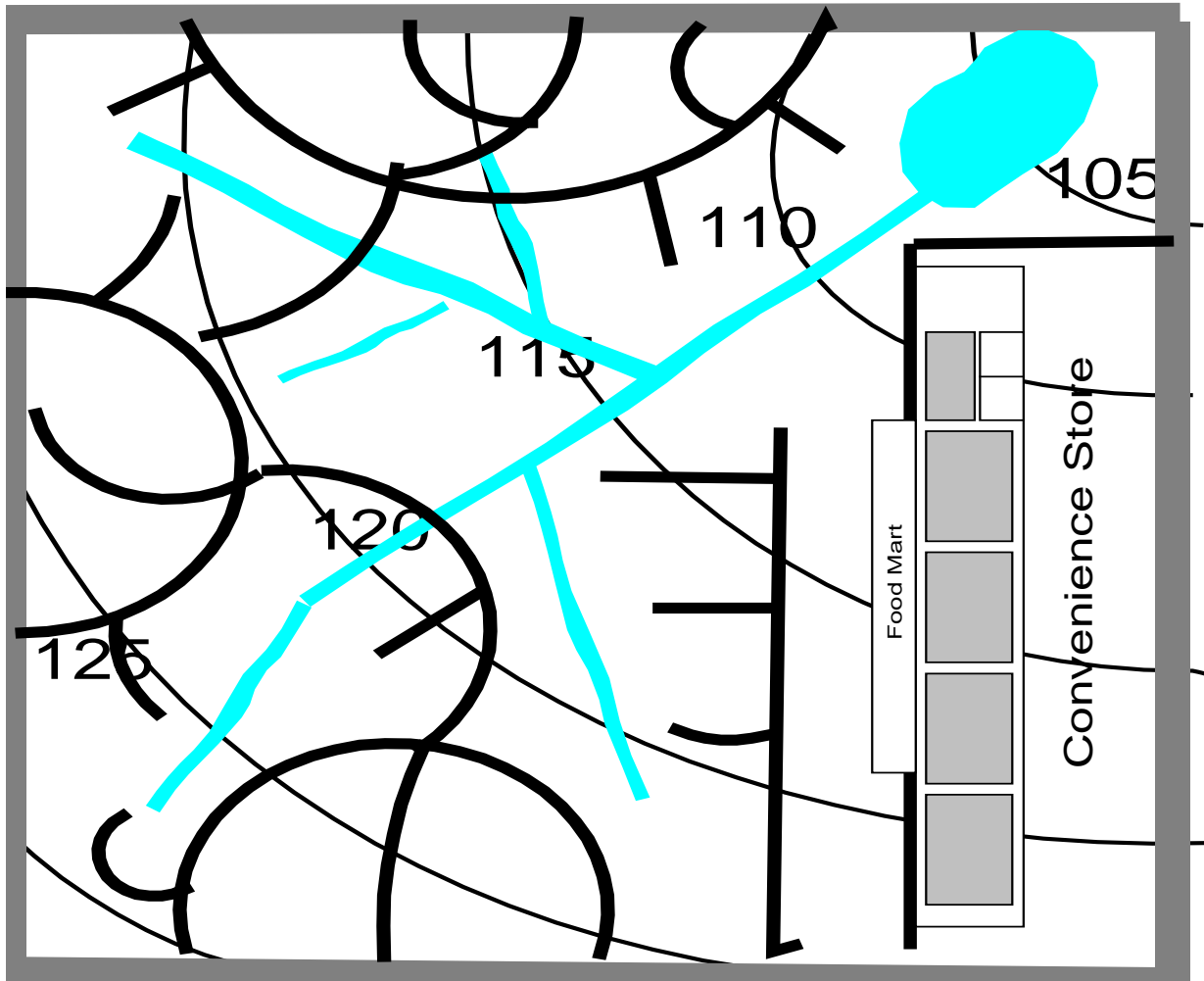

**Table 5.73-1 Pond surface area required as a percent of drainage area, for a given land use and goal of 90% sediment removal (Pitt, 1998)**

Land Use	Percent of Watershed
Totally Paved Areas	3.0
Freeways	2.8
Industrial Areas	2.0
Commercial Areas	1.7
Institutional Areas	1.7
Construction Sites	1.5
Residential Areas	0.8
Open Spaces	0.6

*Step 2. Find the required pond layout and surface area.*

### Pond Layout

Analysis of runoff data (Pitt) indicates that the pond size should be based on the surface area and land use because of the effect these factors have on runoff. Pitt recommends using a pond with a surface area of 0.8% of the watershed for residential and 1.7% for commercial. The “Recommended Pond Surface Area” (Table 5.73-1) is a preliminary estimate of pond surface area needed for a wet stormwater-treatment pond.

This is a mixed-use watershed, so the actual size of the pond should be interpolated. Using the above estimates, we use 20 acres x 1.7% of the watershed and 80 acres x 0.8% of the watershed:

$$20 \text{ acres} \times .017 = 0.34 \text{ acre};$$

$$80 \text{ acres} \times .008 = 0.64 \text{ acre};$$

$$\text{Total pond area} = 0.34 \text{ acre} + 0.64 \text{ acre} = 0.98 \text{ acre} \approx 1.0 \text{ acre}.$$

Based on the calculations, we select a pond, for demonstration purposes, with 1.0 acre of open water, which is about 1.0% of the watershed.

For comparison purposes, we can look at several local criteria. Based on various sizing criteria for water quality treatment in ponds, the following minimum values would be necessary:

Dual Purpose (Dry Ponds, Klein)	= 0.5 acre	Minimum area required by RMWD
Ramsey Metro Watershed District	= 0.5 acre	Minimum area required by RMWD
Pitt (above)	≈ 1.00 acre	Design guidance listed above
MPCA permit	≈ 1.00 acre	Approximation from Pitt
Metropolitan Council (Oberts)	2.0 acres	Recommended surface area pond / watershed ratio = (2% of watershed)
Pond Wetland (Schueler)	2.0 acres	2.0% of watershed area
Vadnais Lakes Area Watershed Management Organization (Walker)	≈ 1.0 to 2.0 acres	Volume-divided-by-depth calculation
Note: ≈ means approximately, usually that the size is not specifically given but can be calculated from other design factors or recommendations.		

The following calculations for the pond area are based on the above design requirements. For simplicity, we assume that the pond is approximately circular.

**Radius of a 1.0-acre pond:**

$$A = \pi r^2$$

$$43,560 \text{ ft}^2 = 3.14 (r^2)$$

$$43,560 \div 3.14 = r^2$$

$$r^2 = 13,873$$

$$r = 117.8 \approx 118 \text{ ft}$$

Note: To get some idea of the routing, an iterative process is proposed. A 2.5-acre set-aside for a pond is tried: 1.0 acre for permanent pond and 1.0 acre for bounce. In addition, there will be setback restrictions on development structures so they are 2.0 ft above the 100-year event. A dike that limits the expansion of the bounce could be proposed, but it would be costly, and a more natural landscape would be more aesthetically pleasing. Also, the infrequently flooded areas can be used as common recreation area, natural buffer area or open space.

### ***Step 3. Calculate the extended detention volume of the pond.***

#### **The Volume above the Outlet, or the Bounce**

The amount of area needed for bounce needs to be determined in steps. The outflow is limited by MPCA permits and by other policy requirements placed on the system, especially flood-control policy.

#### **Definition**

The water quality volume is a calculation based on the runoff from a 1.25-inch precipitation event, or the 0.5 inch of runoff from the impervious areas.

The water quality treatment volume is to be considered a specific volume, not an inflow-outflow calculation. Another way to put this is that it is an instant volume provided for treatment in addition to the permanent storage; usually provided above the outlet of the basin. It can be included in the volume below the outlet if the permanent storage is at least twice the water quality volume or runoff from the 2.5-inch event. This takes into account a volume for scour and treatment.

#### **Water Quality Volume Calculations**

For this example, we will use the MPCA permit method as the first estimate of the water quality volume. **The MPCA permit method uses 0.5 inch of runoff from all impervious surface (connected and unconnected):**

Residential area of 80 acres x .30 (fraction impervious) x 0.5 inch x 1/12 ft/inch = 1.0 acre ft ( $V_1$ )

Commercial area of 20 acres x .85 (fraction impervious) x 0.5 inch x 1/12 ft/inch = 0.7 acre ft ( $V_2$ )

Total treatment volume =  $V_1 + V_2 = 1.70$  acre ft (See Note 5.73-1, Comparisons of Methods, for other calculations of this volume.)

#### **Maximum Water Quality Treatment Discharge Rate**

$Q_{out} \leq \text{Pond Area (in acres)} \times 5.66$  cfs per acre

As noted in part 5.03, Barfield (1988) recommended an outflow rate to surface area design. Pitt (1994) found that a ratio of approximately 5.66 cfs of outflow for each acre of pond surface area resulted in a predicted sediment trapping efficiency of approximately 90% in urban storm water.

The national treatment goal for wet ponds is to remove about 90% of the suspended solids. Thus, a minimum ratio of 5.66 cfs of pond outflow per acre of pond surface area is recommended.

#### **Peak Discharge Volumes**

Controlling the two-, 10- and 100-year events starts with finding the predevelopment discharge rate for these storm events.

#### **Two-year Event Control**

As described in the planning section, it is recommend that the two-year event be discharged at  $\leq 0.5$  the predevelopment rate. The postdevelopment peak discharge for the two-year events should be released from stormwater ponds at one-half of the two-year peak discharge for the predevelopment watershed conditions.

### Note 5.73-1 Comparison of Methods

As you will see, the calculation of runoff volume is not precise or accurate. Precision is getting the same result with each method or between each method. Accuracy, or accurate prediction of what will happen with a given event, requires knowledge of the actual site and therefore will always be subject to professional judgement and interpretation.

The following provides three methods to determine the water quality volume. The method used to design the pond should reflect good treatment that meets the outflow rate for at least an actual, calibrated 1.25-inch storm event. These examples have been simplified, but they illustrate some of the problems that will be encountered in actual design calculations.

In each example, notice that not only are the volumes different, but the fraction that each part is expected to contribute also changes. Areas that are mostly impervious or mostly undeveloped can often be considered homogeneous. The contribution of the highly impervious commercial area is very similar using either method. Mixed-use areas are very difficult. If a residential area actually has a high percentage of connected impervious surface, it would be expected to contribute more runoff at low-volume storm events. The examples demonstrate this characteristic of runoff analysis.

#### Calculations using 1.25-inch rain event (weighted NRCS method)

Treatment volume for:

Residential area of 80 acres x .0375 inch runoff (weighted CN of 72) x 1/12 ft/inch = 0.25 acre ft

Commercial area of 20 acres x 0.5 inch (weighted CN of 92) x 1/12 ft/inch = 0.8 acre ft

Total volume = 0.25 acre ft + 0.8 acre ft = **1.05 acre ft**

(The TR55 manual indicates that these are connected impervious surfaces, but as you see below, we do not recommend this be assumed unless there is actually substantial unconnected impervious surface.)

#### Calculations using NRCS methods (but assume all impervious is a connected subwatershed)

Residential impervious areas: 80 acres x .3 x 1 inch x 1/12 ft/inch = 2 acre ft ( $V_1$ )

Commercial impervious area: 20 acres x .85 x 1 inch runoff x 1/12 ft /inch = 1.4 acre ft ( $V_2$ )

Residential and commercial pervious areas: (use CN of 61) x = 0.0 runoff acre ft ( $V_3$ )

Total treatment volume =  $V_1 + V_2 + V_3 = 2.0 + 1.4 + 0.0 = \mathbf{3.4 \text{ acre ft}}$

**Calculations using NRCS TR20** with inputs from the site including two subwatersheds, but a weighted curve for the residential area = **1.33 acre ft.**

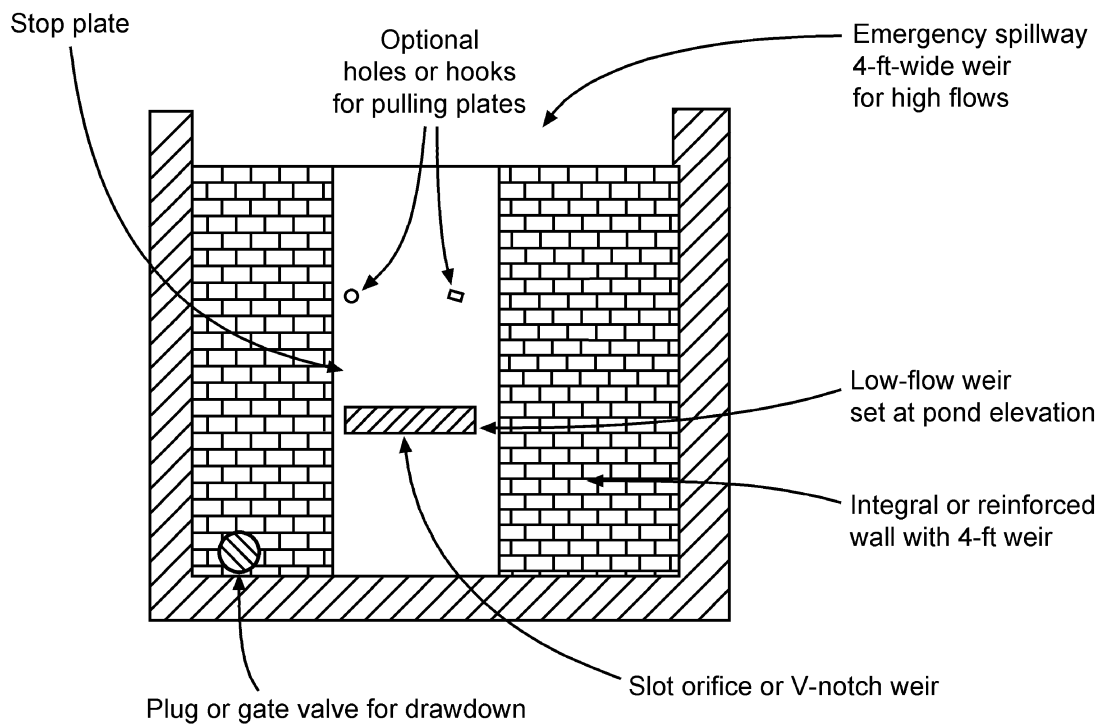
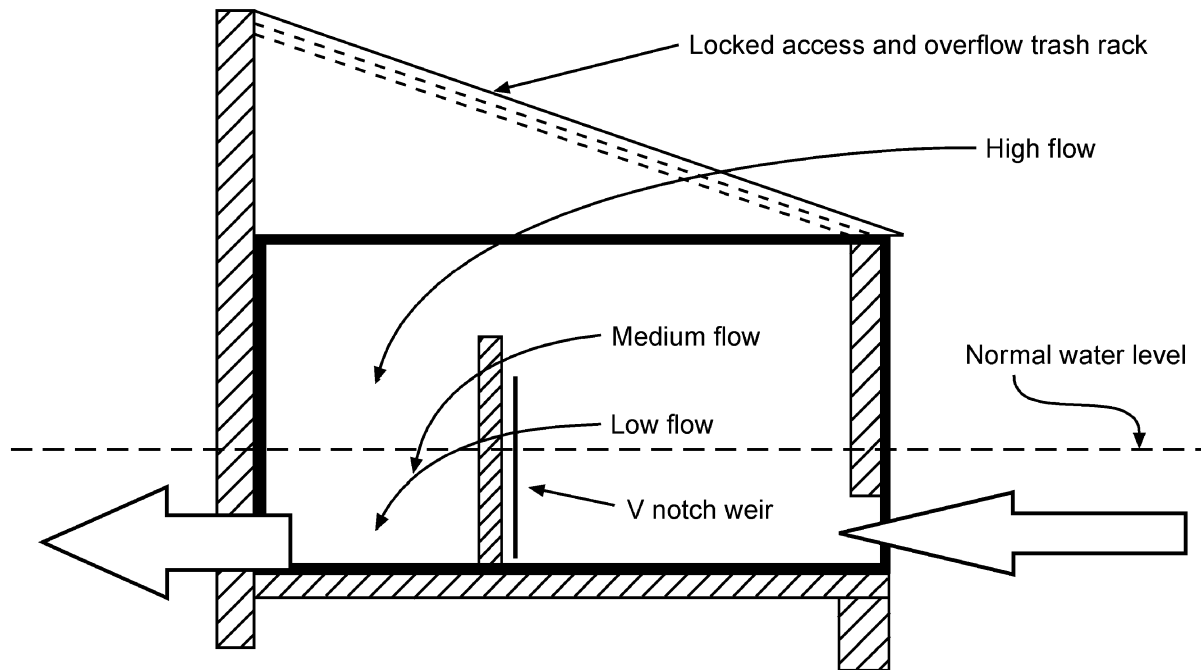

**Figure 5.73-1 Schematic of outfall structure**

## Flood-control Goal

**Criteria for two-year through 100-year precipitation events.** Most watersheds require that postdevelopment runoff must equal the 10- and 100-year, 24-hour predevelopment events. Structures often must be 0.5 to 3.0 ft above the 100-year flood event. The topography and/or policy usually indicate that the bounce be limited to less than 6 ft.

## Flood calculations

The following are the parameters estimated from data in step 1:

Predevelopment curve number, or CN (NRCS, 1986) = 61.

Time of concentration (T of c) = the sum of the times of travel (T of t).

T of t for sheet flow (0.32 hr) + T of t for concentrated flow (0.41 hr.) = T of c = 0.73 hr.

Based on the above conditions, using TR20 to calculate the predevelopment runoff conditions, we calculate the following:

Peak flow for a predevelopment 2-year event = **9.3 cfs.**

Therefore, one-half of the predevelopment 2-year event = 4.65 or ~ **4.7cfs.**

Peak flow for predevelopment 10-year event = **48.3 cfs.**

Peak flow for a predevelopment 100-year event = **120.5 cfs.**

## Proposed Conditions

Using a water quality volume of 1.7 acre ft, the runoff from the residential area will be approximately equal to the predevelopment conditions. However, the CN for the commercial area will be 92. Time of concentration (T of c) will be about 800 seconds, or 0.22 hr. The residential area can use a composite CN of 72, although this is questionable if many impervious surfaces are directly connected to the drainage system.

## Pond Outlet Design

Once the pond area and outflow rates have been established, the outlet area needs to be designed and sized. It is hoped that the size can be approximated and an iterative process set up to refine the design details. A stage discharge curve is usually established for a given outlet design, then a model is run to determine whether the peak outflows for the water quality volume and the two-, 10- and 100-year events are at or below the applicable criteria.

Outlet or spillway design is a key element for stormwater treatment and for controlling flood discharges. It also affects the velocities in the pond. The design must reflect the discharge limitations on water quality volume, two-year, 10-year and 100-year event restrictions. It also must meet the design features described in part 5.06. The key features are access, maintenance and flow control.

Table 5.73-2 shows the result of the calculations needed to design the pond, based on the hydraulics.

Using the project described above, the outlet can be inserted into a model or other design method using an assumed design. An iterative method can be used to refine the design estimates to better meet project requirements and goals. After several outlet designs had been tried, **we recommend**

**Table 5.73-2 Stage discharge area table**

Stage	Radius	Area	Average area in acres	Storage in acre ft	Discharge in cfs	Criteria	Basis
100.00	118.00	1.00	0.00	0.00	0.00	5.68	Water Quality Vol.
100.50	123.00	1.09	1.05	0.52	1.89	6.18	Water Quality Vol.
101.00	128.00	1.18	1.14	1.09	2.67	6.69	Water Quality Vol.
101.20	130.00	1.22	1.15	1.33	2.92	6.90	Water Quality Vol.
101.50	133.00	1.28	1.25	1.70	3.27	7.22	Water Quality Vol.
102.00	138.00	1.37	1.32	2.37	3.77	9.30 (4.7)	2-yr Discharge
102.50	143.00	1.47	1.42	3.08	4.22	9.30 (4.7)	2-yr Discharge
102.92	147.20	1.56	1.52	3.72	4.56	9.30 (4.7)	2-yr Discharge
103.00	148.00	1.58	1.57	3.84	4.62	9.30 (4.7)	2-yr Discharge
103.50	153.00	1.69	1.63	4.66	4.99	48.27	10-yr Discharge
104.00	158.00	1.80	1.74	5.53	17.64	48.27	10-yr Discharge
104.50	163.00	1.92	1.86	6.46	27.63	48.27	10-yr Discharge
104.92	167.20	2.02	1.96	7.28	37.02	48.27	10-yr Discharge
105.00	168.00	2.04	2.02	7.44	38.90	120.46	100-yr Discharge
105.50	173.00	2.16	2.10	8.49	51.06	120.46	100-yr Discharge
106.00	178.00	2.29	2.22	9.60	63.82	120.46	100-yr Discharge
106.16	179.60	2.33	2.30	9.97	67.99	120.46	100-yr Discharge
106.50	183.00	2.42	2.37	10.78	76.94	120.46	100-yr Discharge
106.66	184.60	2.46	2.44	11.17	81.19	120.46	100-yr Discharge
107.00	188.00	2.55	2.50	12.02	90.24	120.46	100-yr Discharge

using a 1-ft-by-4-inch slotted outlet in a 3.5-ft-high wall, with 4-ft weir overflow. The recommended outlet gives the results for computer runs using the assumptions of proposed conditions and recommended outlet design seen in Table 5.73-2.

**Step 4. Calculate the storage volume below the outlet from the pond.**

After the extended detention volume has been determined, the second set of volume calculations that must be addressed in the pond design is “storage volume.” This includes sediment volume and permanent pool. Permanent pool volume includes a stilling component for velocity control and a resuspension-control component. In addition, the storage volume may encourage biochemical removal of phosphorus and/or quiescent treatment if the water quality treatment volume of the pond is “oversized.”

For a 1-acre pond of approximately circular shape:

- r = 118 at surface of pond
- r = 108 at the base of the 10-ft bench (see Step 2)
- r = 102 at the bottom of the pond

### Volume below the outlet:

$$Vol = \left( \frac{r_1 + r_2}{2} \right)^2 \times 3.14 \times d$$

$$V_1 = \left( \frac{102 + 108}{2} \right)^2 \times 3.14 \times 2 = 69,237 \text{ ft}^3$$

$$V_2 = \left( \frac{108 + 118}{2} \right)^2 \times 3.14 \times 1 = 40,095 \text{ ft}^3$$

$$V_t = V_1 + V_2 = 69,237 + 40,095 = 109,332 \text{ ft}^3$$

$$V_t = 109,332 \text{ ft}^3 \div 43,560 \text{ ft per acre} = 2.5 \text{ acre feet}$$

This example uses a standard design method, and is for illustration only. Many volume designs, including wetland designs or deeper ponds, can be used. Each has its advantages and drawbacks, as addressed in the discussion in this manual.

### Bench Design

All ponds should be designed with a bench at 10:1 slope around the edge of the pond, starting at the normal water level. This can be included in the treatment area for most pond designs. The normal slope of a wet pond, inside the bench is 3:1, usually to a depth of 2 to 8 ft. Average pond depth in the treatment area is therefore often about 3 ft. The actual average depth can be 2 to 6 ft if proper design precautions are used.

### Sediment Storage Design

Sediment volume should be at least the MPCA permit requirement of 250 cubic feet (ft<sup>3</sup>) per acre of impervious surface. It can be built with capacity for about 25 years of storage. A detailed analysis of pond sediment storage volume may be helpful to determine cost-effective sediment control plans. Methods such as the NRCS use equations that address many of the sediment storage factors, but they should be evaluated by professionals on a site-specific basis. The basic equation and design considerations are:

$$Vol = \frac{E \times DR \times TE \times A \times Y}{217,800 \times G}$$

where: Vol = design sediment storage capacity,

*E* = average rate of erosion in the watershed in tons/acre/year,

*A* = area of the watershed in acres,

*DR* = sediment delivery ratio in percent,

*G* = estimated sediment density in the basin in pounds per cubic foot,

*TE* = trap efficiency, in percent, and

*Y* = design storage period in years.

### Pond Inlet Area Design

At least 10-20% of the area of the pond should be allocated to the inlet area. Design features should include consideration of all the factors considered in the manual. The inlet area depth should be at

least 3 ft deep and at maximum up to 8 ft deep, depending on the inlet flow and pipe size. The depth should be two times the pipe size for designs that provide dispersion by plunge only. With pipes over 3 ft in diameter, consider having diffusion structures, oversized pipes, concrete walls, berms or other physical measures to create flow dispersion.

### **Outlet Area Design**

The outlet area is recommended as part of the wet pond design. A stilling pool 3 to 8 ft deep usually provides 10-20% of the pond volume, depending on the treatment area design. It usually is located in front of the outlet and is sized to reduce outflow velocities to levels that prevent scour and resuspension.

### **“Oversized” Ponds**

Oversized ponds are designed to include the water quality volume in the permanent pool below the outlet. As has been discussed, in section 5.30 we recommend that this volume provide storage for an event twice the water quality volume, or the runoff from the annual event, which in the metropolitan area is about the 2.5-inch event. Note that the water quality volume is based on an instantaneous volume, not a storage-discharge calculation. Also, the calculation is not twice the water quality volume, but an event twice as large as the water quality event.

Past practice has shown that a smaller volume (*i.e.*, the 2.0-inch event) can be used as an alternative to the 2.5-inch size criteria if the sediment volume is “oversized” to provide 25 years of storage based on NRCS sediment storage calculation methods (see below).

Oversized ponds do not need to meet the outflow rate requirements for the water quality volume, but generally the water quality storm will have a peak discharge less than the water quality outflow rate of 5.66 cfs per acre of pond surface. To prevent resuspension of sediments, these ponds must meet the velocity requirements in the pond for the 1.25-inch and the one-, two-, 10- and 100-year events. Generally, this can be checked by routing the various storms through the pond. The high-flow events (two-, 10- and 100-year events) should also have peak discharges less than the predevelopment discharge, or other rate set by local policy.

### **Wetlands**

Wetlands are another option that can be used in place of an open pool. We encourage the use of wetlands for treatment, but detailed designs of wetland treatment systems is beyond the scope of this manual. We refer you to Schueler and others in the references within this chapter.

### ***Step 5. Address special design considerations.***

Special design considerations should address design features described in part 5.08. These include:

Water Quality Standards	Wetland Conversion
Ground Water Pollution	Constructed Wetlands
Pollutants in Sediments	Wetland Replacement
Sediment Removal	Other Regulations
Permitting Requirements	Design for Small Watersheds
Dam Safety Requirements	Design for Winter Runoff Conditions
Wetland Impacts	Dry-weather Flows
Natural Wetlands	

***Step 6. Address aspects of operation and maintenance.***

Operation and maintenance of fences, sediment, erosion, and vegetation must be addressed as described in part 5.07.